

SCALAMID

FACADE • FLOOR • WALL

installation guide | **facades**

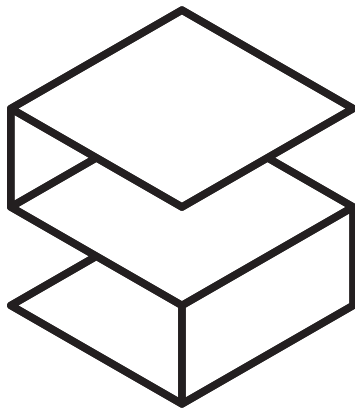

SCALAMID

| | |
|---|-------|
| processing and storage | 02 |
| SCALAMID cladding – ways of the installation | 03 |
| A mechanical connections – rear shear anchors | 04-07 |
| B adhesive connections | 08-13 |
| C mechanical connections – blind rivets | 14-18 |
| D mechanical connections – screws | 19-24 |
| finishing profiles | 25 |
| use of finishing profiles | 26-27 |
| ways of finishing the wall corners | 28-30 |
| construction details of ventilated facades on an aluminium substructure | 31-34 |
| construction details of ventilated facades on a wooden substructure | 35-38 |

processing and storage

DRILLING

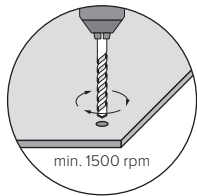

- The holes in the panels should be drilled from the front side of the panel in order to avoid chipping of the material.
- Use diamond drill bits dedicated to fibre-cement panels.
- The rotation speed of the drill should be 1500 rpm.

CUTTING

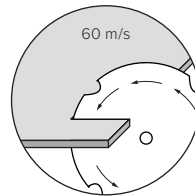

- Due to dusting, cutting panels should be performed using devices equipped with a drainage system for the dust created during the processing of cement and dust masks.
- Fibre-cement panel cutting discs should be used for cutting the panels, working with a speed of not less than 60 m/s.
- This guarantees a uniform and sharp edge which should be „deburred“ and sanded with sandpaper.
- For deburring any sharp edges use sandpaper with a minimum grade of 600.

IMPREGNATION

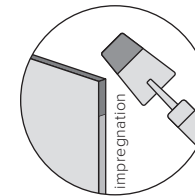

- All cut and sanded edges should be impregnated with the primer recommended by the manufacturer.
- Before applying the impregnation, make sure that the surface is dry, dust-free and dirt free.
- The temperature of the panels and the environment should be at least 5°C.
- The impregnation should be applied to the edges of the panels with an applicator. The excess impregnation can be wiped off with a cloth made of microfibre.
- Installation of panels should be carried out after the impregnation has dried..

STORAGE CONDITIONS

- SCALAMID panels should be stored on transport pallets placed on a flat, dry and equal surface.
- Stacked panels must be stored inside, in ventilated rooms or be covered (tarpaulin or shed) in dry conditions, providing protection against adverse effects of weather conditions.
- A maximum of 5 pallets may be stacked.
- Storage under a plastic cover carries the risk of water condensation due to high temperature and lack of ventilation.

TRANSPORT

- SCALAMID sheets should be transported in a vertical position, which guarantees their stiffness.

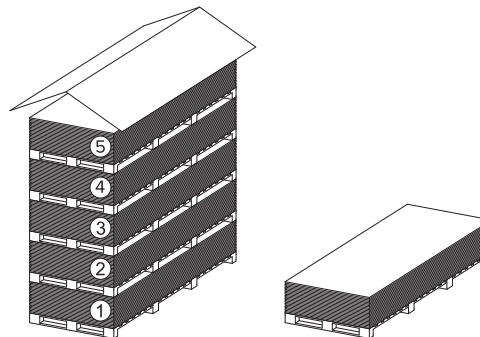

CAUTION!

- Carrying the boards in horizontal position may strain their structure and cause damage.
- Never drag the boards over the ground to prevent scratches and mechanical damage.

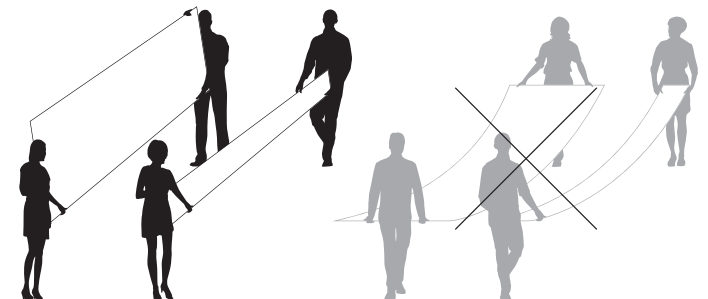

SCALAMID cladding ways of the installation

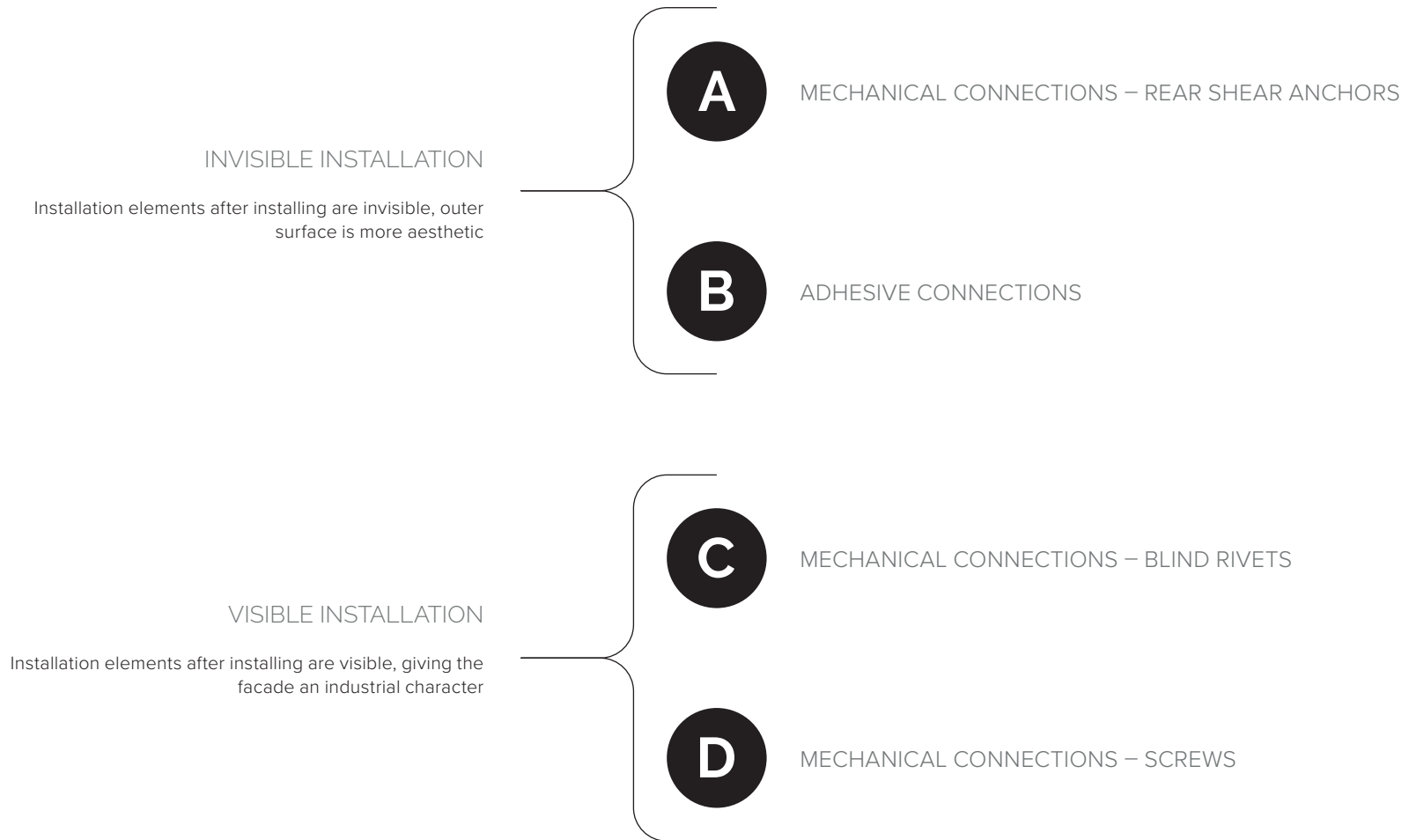

A

installation with back screws

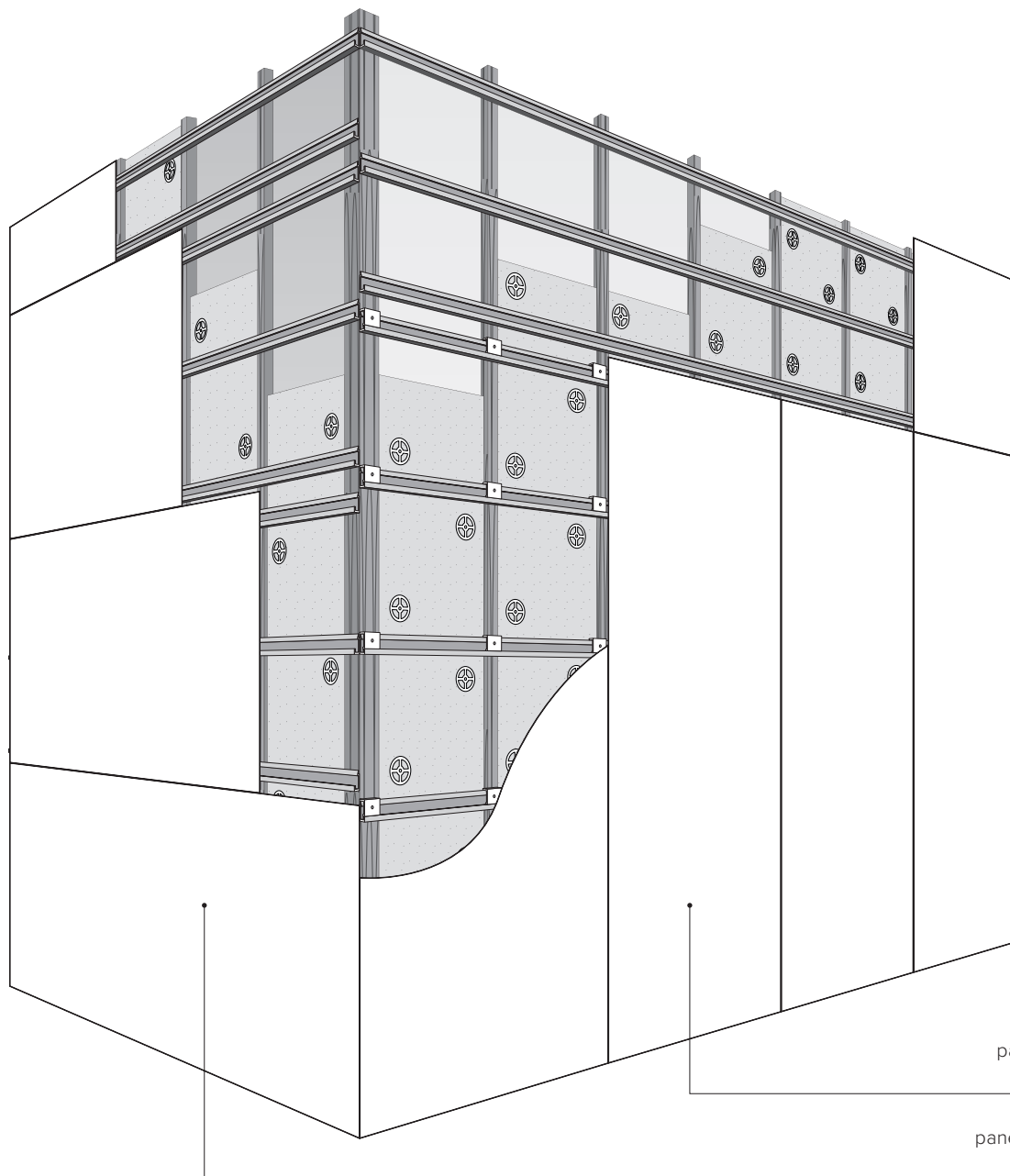

TYPE OF SUBSTRUCTURE

The rail mounting system can be used on a wooden or aluminum substructure.

PANEL LAYOUT

The panels can be fixed either vertically or horizontally as recommended by the rail system manufacturer.

If proper ventilation behind the panels is not provided (e.g. the panel touches the substrate), the first ventilation grout should be located at a height of 60 cm.

panels mounted vertically on the rail system

panels mounted horizontally on the rail system

A

installation with back screws

TOOLS AND ACCESSORIES

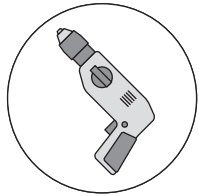

DRILL

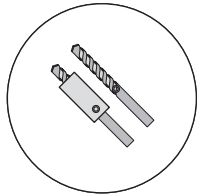

DIAMOND DRILL BITS WITH AND WITHOUT LIMITER

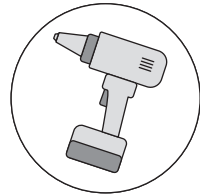

ELECTRIC RIVETER

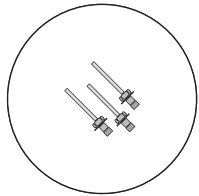

BACK SCREWS (THREADED RIVETS)

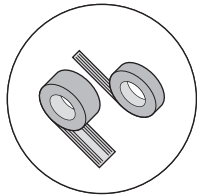

EPDM tape

ASSEMBLY ON A CROSS SUBSTRUCTURE USING THE BACK SCREWS

MOUNTING RAIL

aluminum mounting rail

MOUNTING HANDLES

the handle is a rail section which is attached to the panels with back screws

in the lower parts of the panels it is recommended to mount the handle to one hole in the upper parts of the panel, to two holes

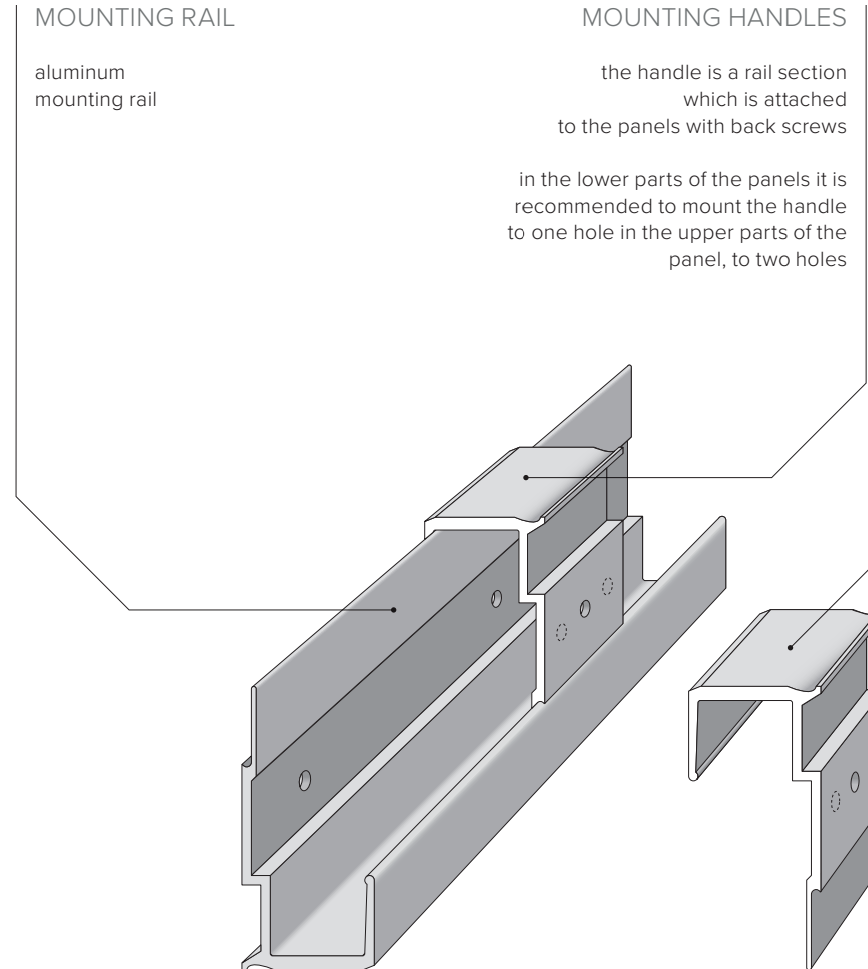

INSTALLATION OF HANGERS IN PANELS

The panels are attached to the base with back screws that remain invisible from the outer side of the cladding.

MOUNTING RAILS TO A WALL OR SUBSTRUCTURE

The rails are mounted directly to the wall or to any type of substructure, according to the design of the solution.

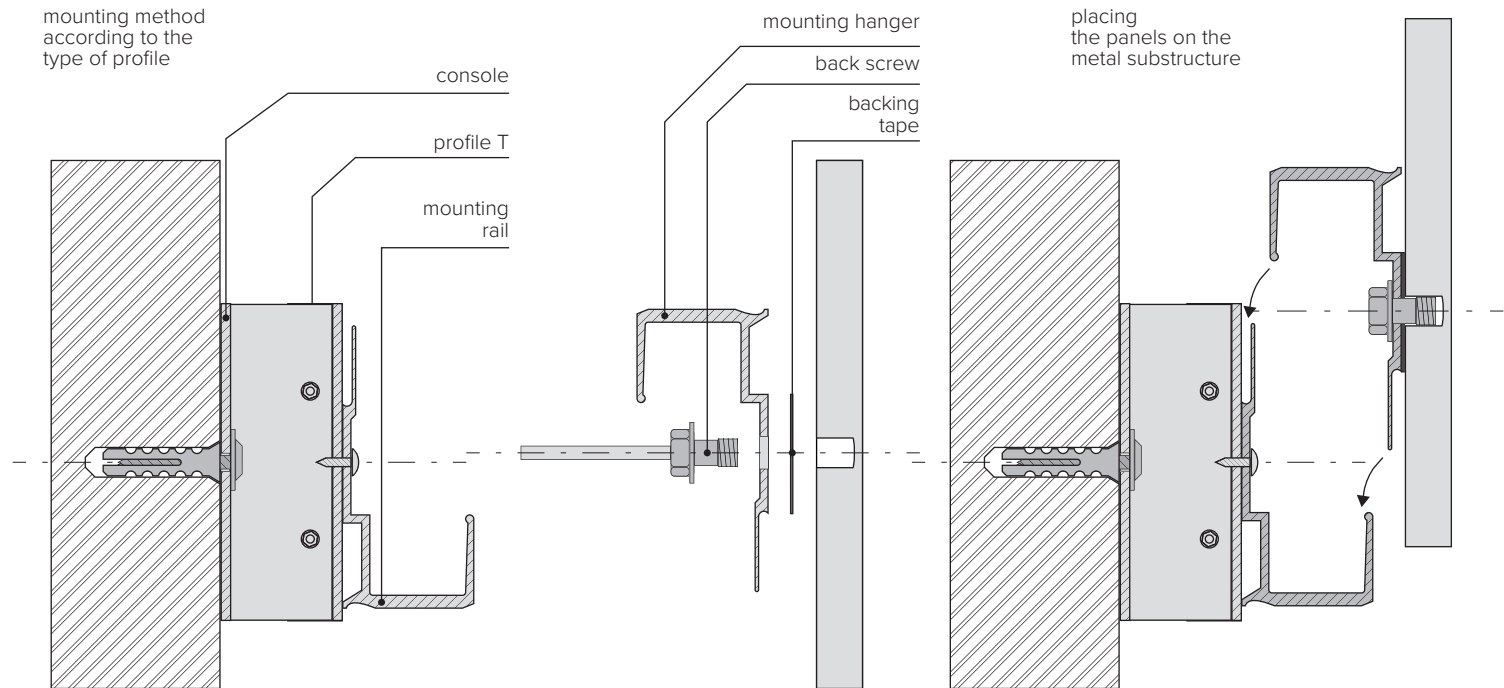
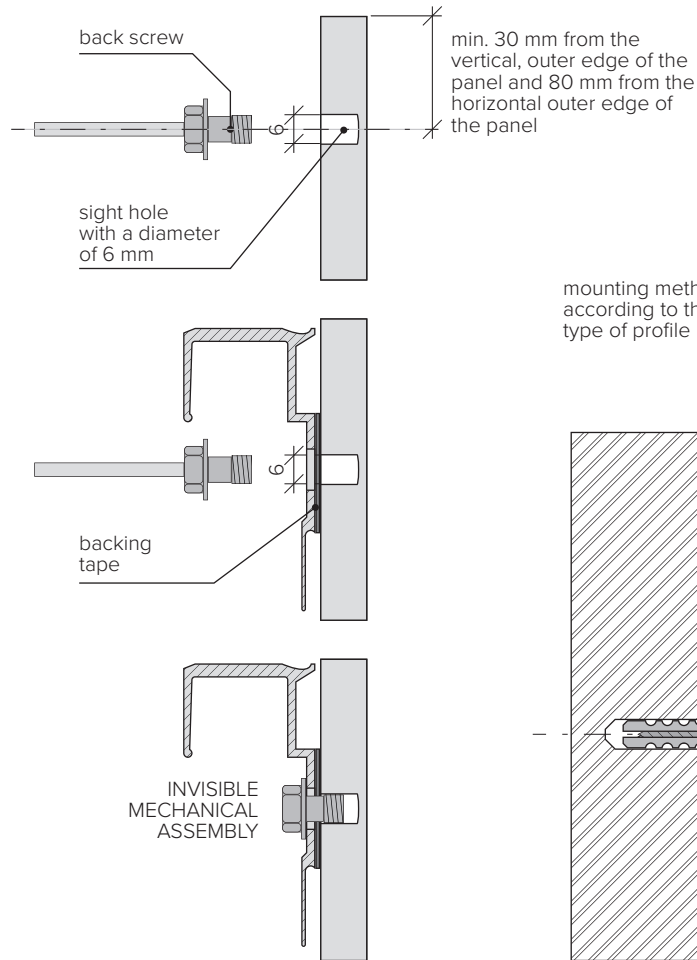

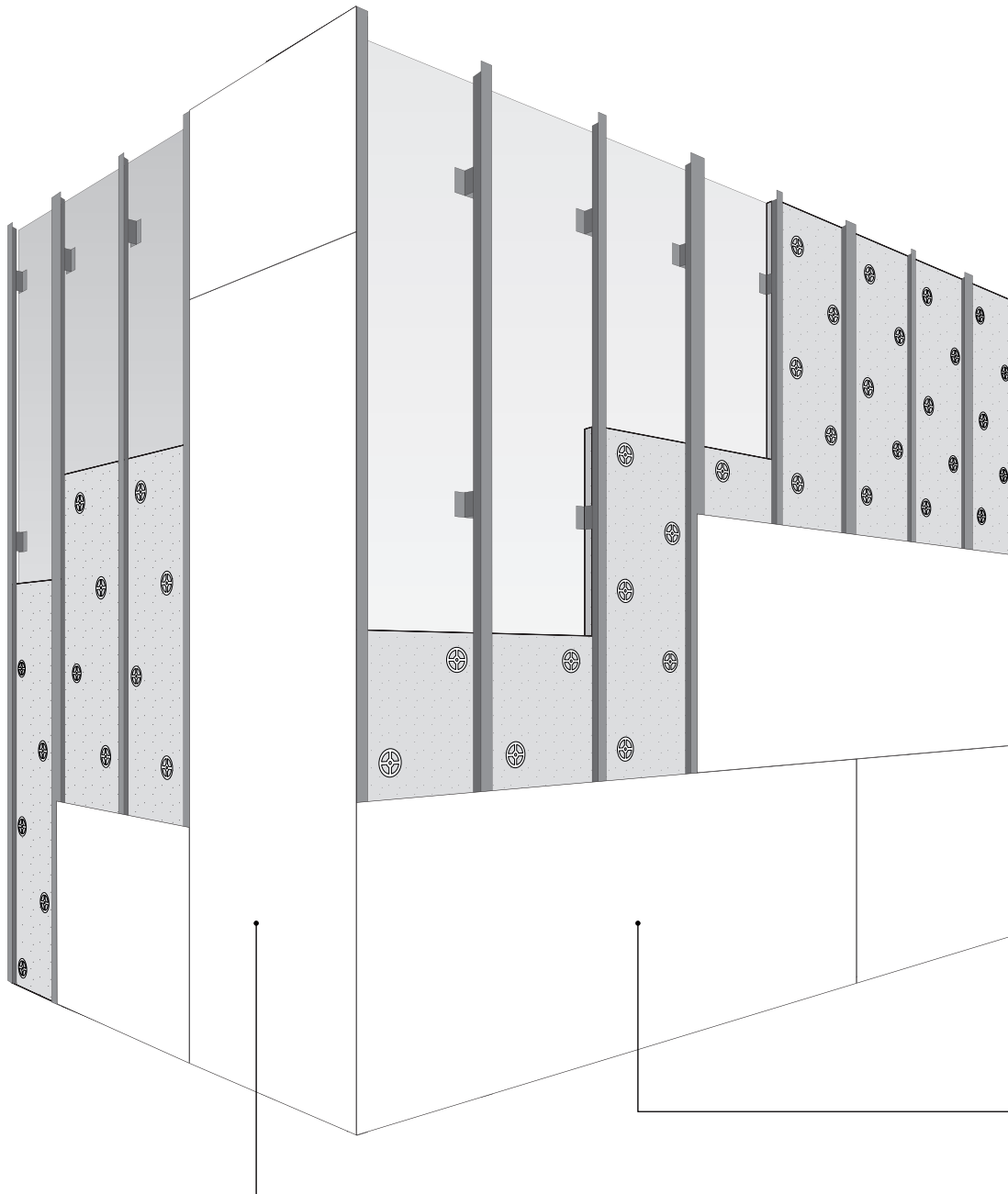

TYPE OF SUBSTRUCTURE

The adhesive mounting system can be used with any type of substructure in a horizontal or vertical orientation, provided the adhesive system is approved for a given substrate by the glue manufacturer.

PANEL LAYOUT

The panels can be mounted in a vertical or horizontal orientation.

If proper ventilation behind the panels is not provided (e.g. the panel touches the substrate), the first ventilation grout should be located at a height of 60 cm.

panels mounted horizontally
on a vertical substructure

panels mounted vertically
on a horizontal substructure

B

adhesive mounting

TOOLS AND ACCESSORIES

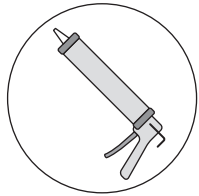

GLUE
SQUEEZER

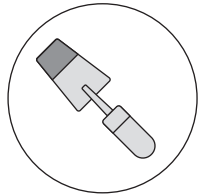

APLICATOR

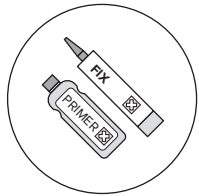

PRIMER AND
MOUNTING GLUE

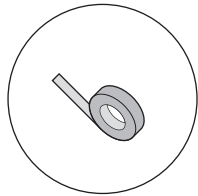

BACKING
TAPE

PANEL MOUNTING

SCALAMID panels can be mounted to a wooden or aluminium / steel substructure with Adhesive connections as per the recommendations of the manufacturer of the given system.

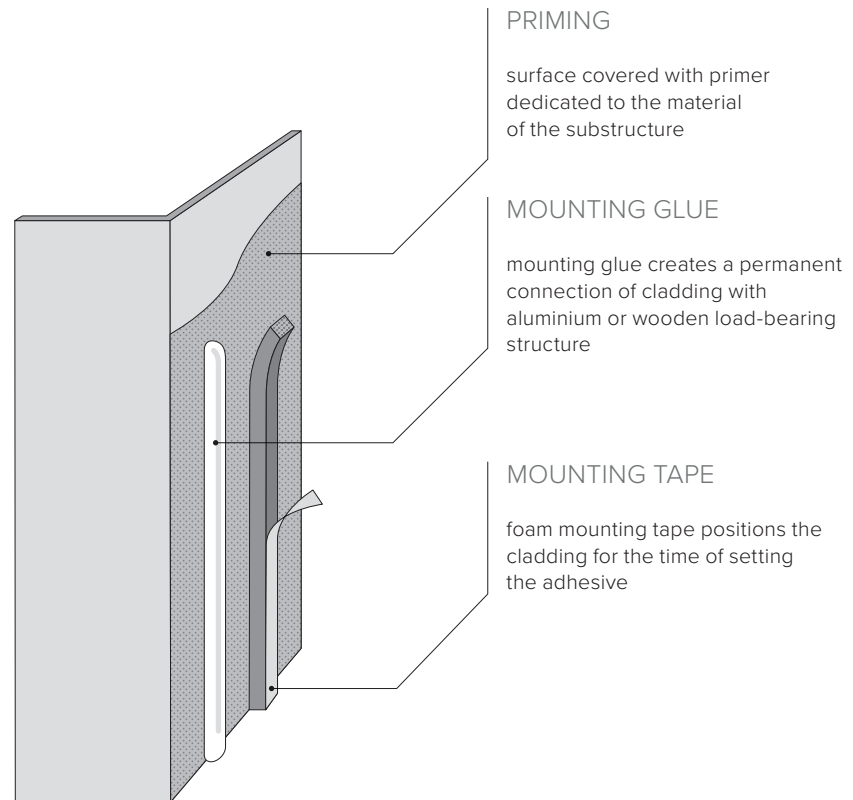

adhesive mounting

METHOD OF MAKING GLUED CONNECTIONS

The assembly of the panels with glue is carried out using mounting adhesive of adequate strength and mounting tape that immediately stabilizes the panels and prevents them from shifting during assembly.

ATTENTION!

Surfaces in contact with the adhesive should be previously degreased and covered with the primer. This applies to both the panel surface and elements of the substructure. Assembly should be done following the recommendations of the adhesive manufacturer

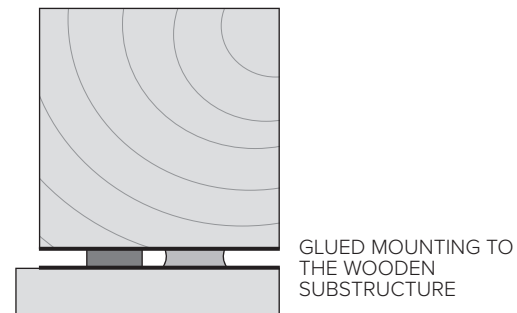
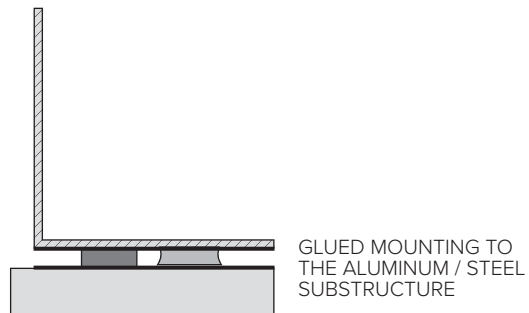
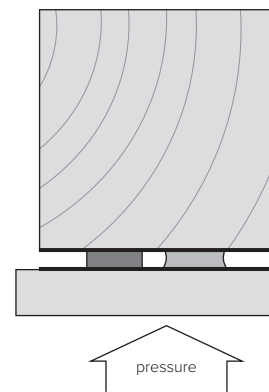
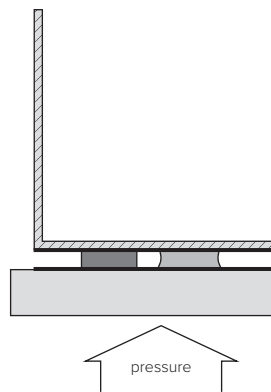
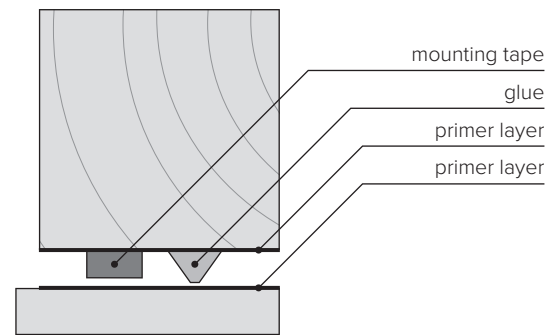
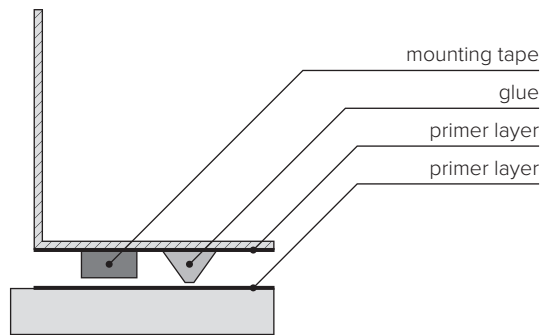

B

adhesive mounting

MOUNTING WITH ADHESIVE TO ALUMINUM / STEEL SUBSTRUCTURE

In glued connections, the mounting tape has a stabilising function during bonding. Tape should always be closer to the edge of the panel than the adhesive layer. Installation is carried out in accordance with the recommendations of the glue manufacturer/supplier.

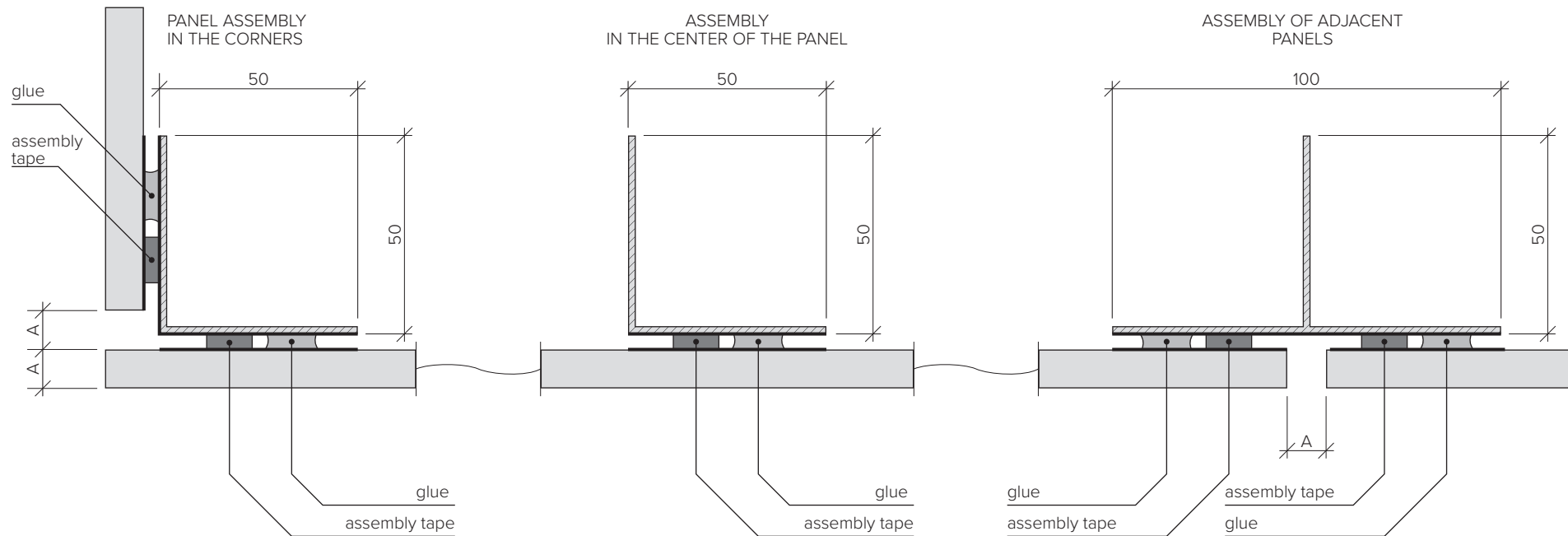
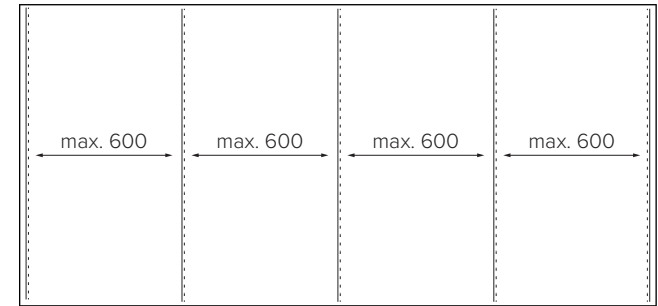

A - min. 8 mm | values are given in millimetres

B

adhesive mounting

MOUNTING WITH ADHESIVE TO A WOODEN CONSTRUCTION

In the case of adhesive connections, the mounting tape stabilizes and protects the adhesive layer during setting and bonding. The tape should always be closer to the edge of the panel than the adhesive layer.

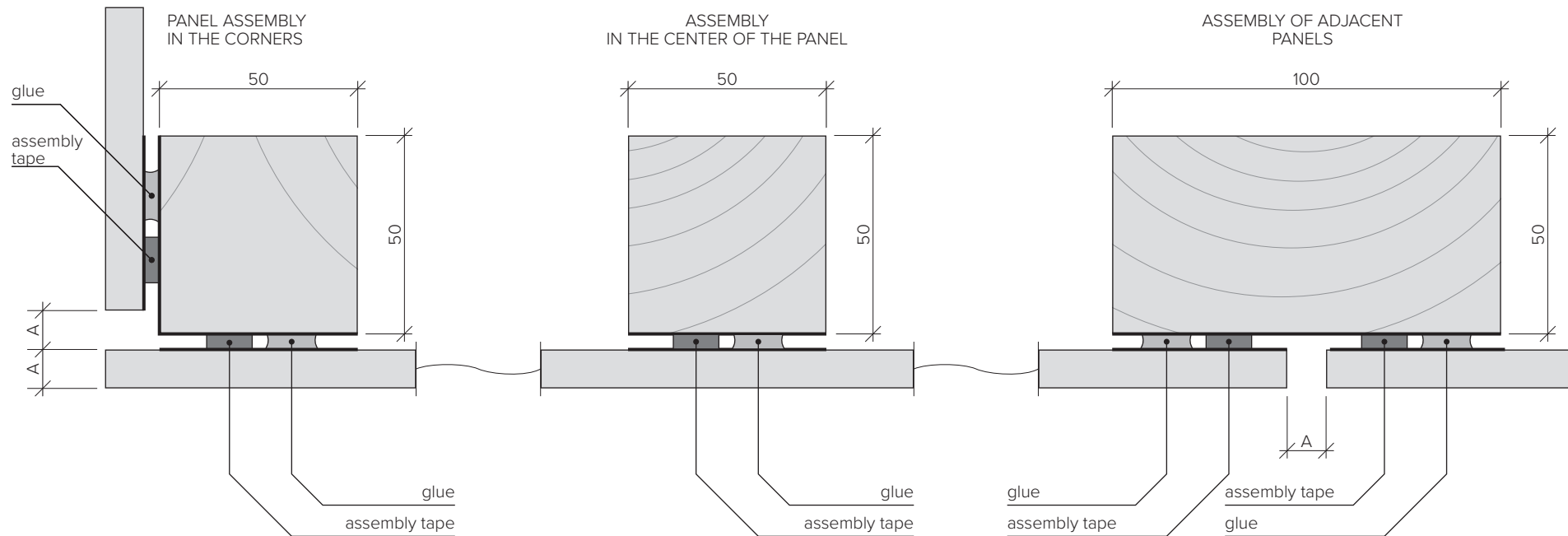
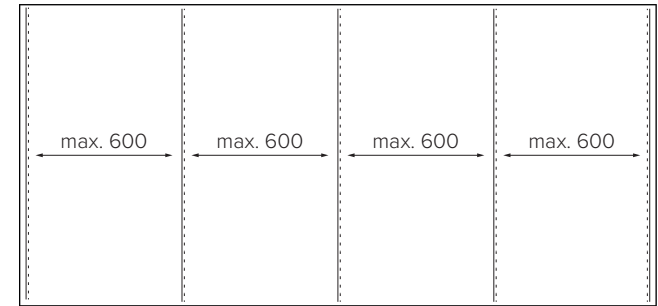

A - min. 8 mm | values are given in millimetres

ASSEMBLY ORDER

The panels should be mounted starting from the top of the wall. If several horizontal rows of panels are laid on one surface, the highest of them should be mounted first.

SEQUENCE OF INSTALLATION WORKS

Panel assembly using adhesive should begin with attaching a temporary starting batten to the substructure and the panels should rest on it during assembly. Accurate levelling of the batten results in levelling the panels. The panels should be pressed first from the bottom edge so as not to change their position in relation to the batten.

After pressing the panels, the batten can be dismantled and used for the next layer of cladding.

VERTICAL ASSEMBLY ON A VERTICAL SUBSTRUCTURE USING THE STARTING BATTEN

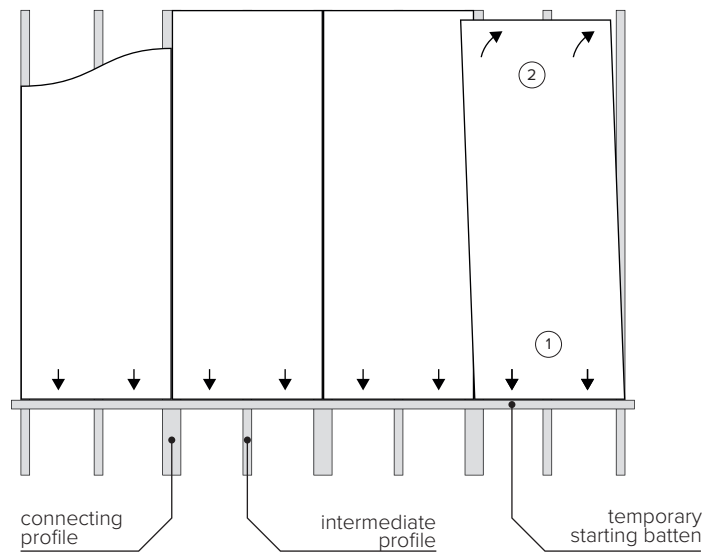

HORIZONTAL ASSEMBLY ON A VERTICAL SUBSTRUCTURE USING THE STARTING BATTEN

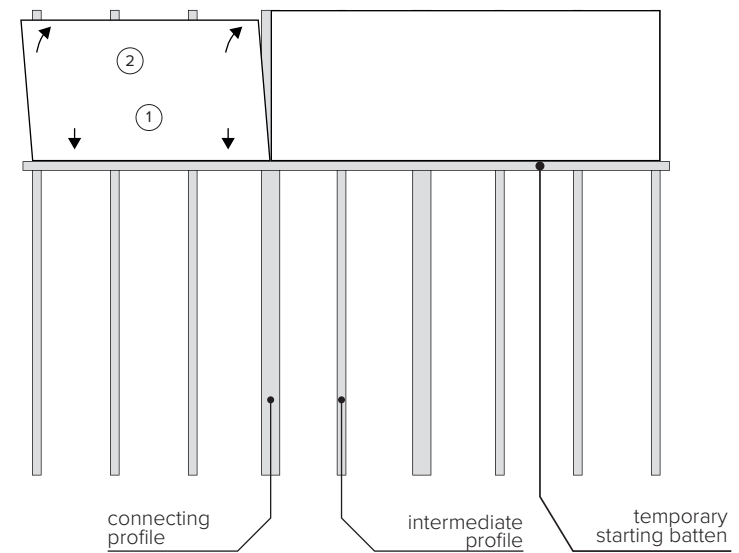



installation with blind rivets

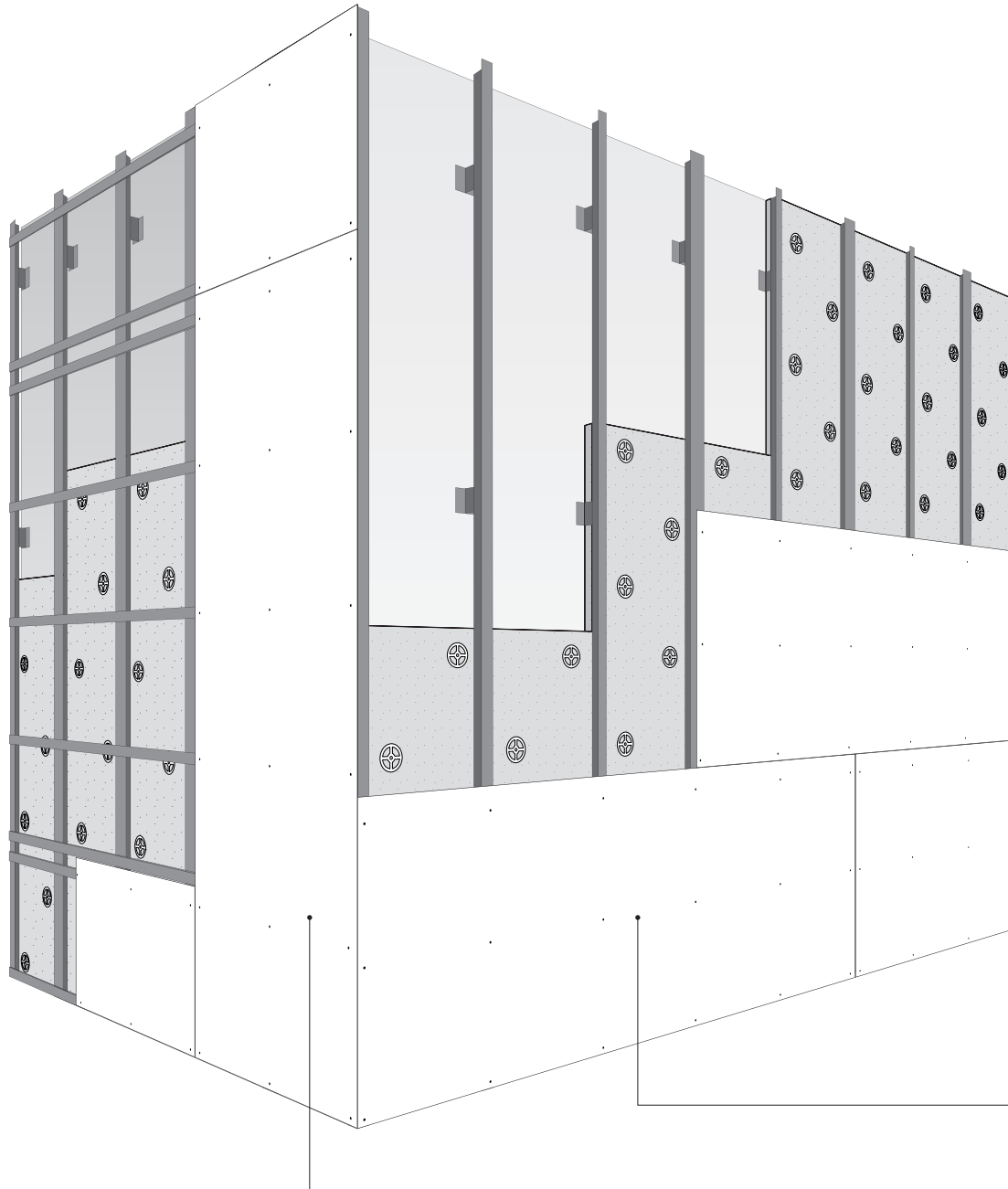

TYPE OF SUBSTRUCTURE

Rivet mounting can be used on an aluminium substructure, vertical or horizontal.

PANEL LAYOUT

The panels can be laid in a vertical or horizontal orientation.

If proper ventilation from below is not provided (e.g. the panel touches the substrate), the first ventilation grout should be located at a height of 60 cm.

panels mounted horizontally
on a vertical substructure

panels mounted vertically
on a horizontal substructure



installation with blind rivets

TOOLS AND ACCESSORIES

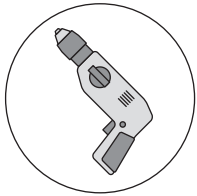

DRILL

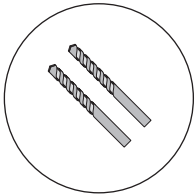

DIAMOND
DRILL BITS

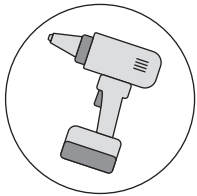

ELECTRIC
RIVETER

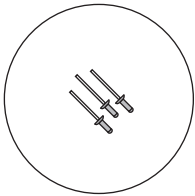

BLIND RIVETS

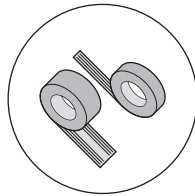

BACKING TAPE

PANEL MOUNTING

Installation with blind rivets to the prepared substructure is made from the front of the panels, and the rivet heads remain visible. Each surface of the panel has fixed and sliding mounting points, which allow for precise levelling of any surface.

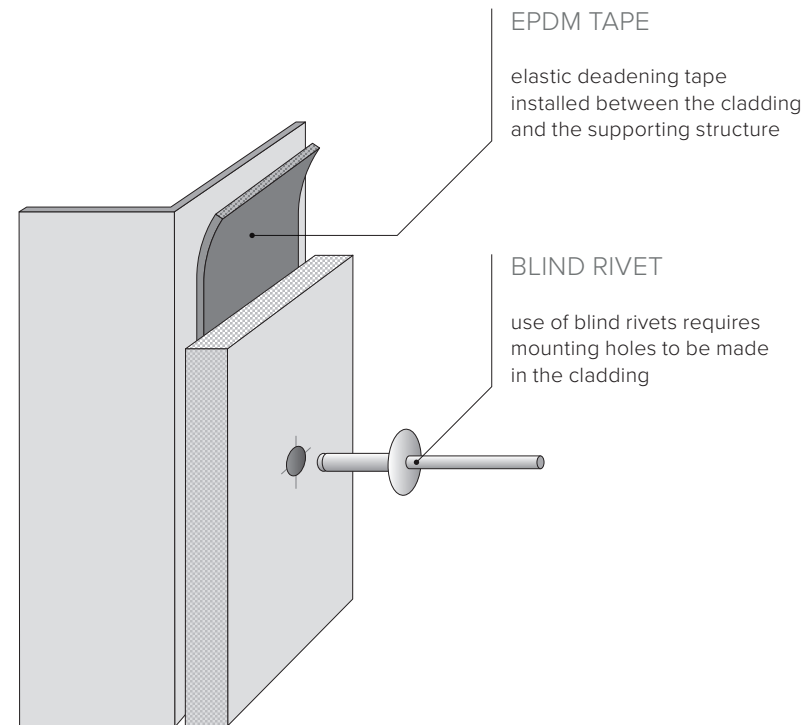



installation with blind rivets

INSTALLATION WITH BLIND RIVETS

The panels are mounted to the substructure with the use of blind rivets with a widened head. In this type of connection **FIXED** and **SLIDING** assembly points are used (see page 17).

The diameter of the holes and the type of rivets should be matched with the detailed design of the facade.

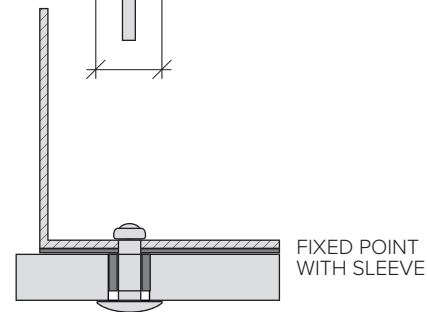
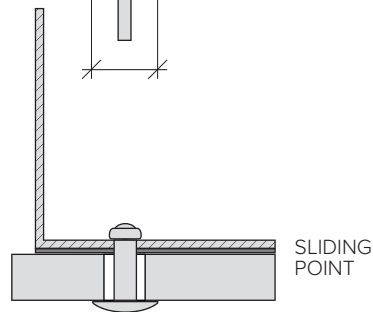
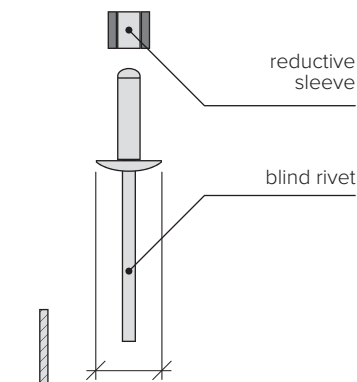
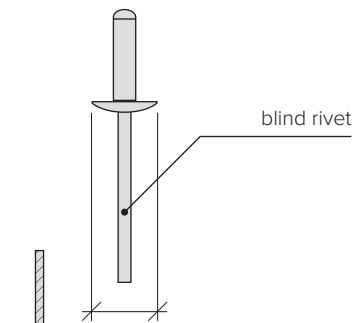
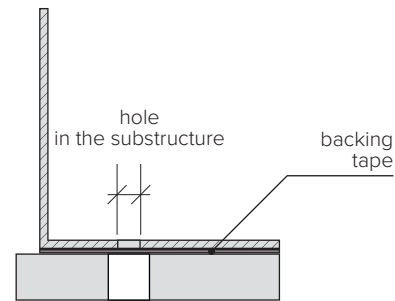
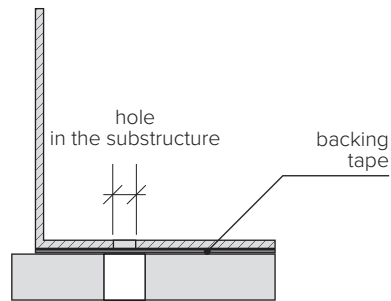
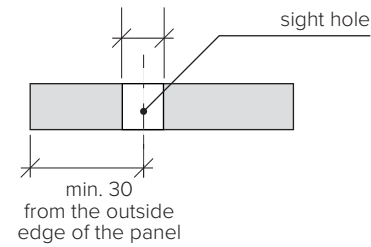
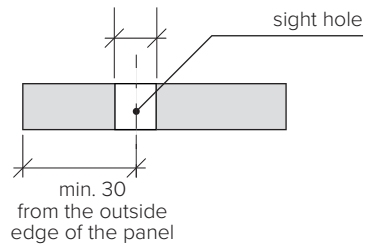



layout of fixed and sliding assembly points

FIXED AND SLIDING ASSEMBLY POINTS

In order to avoid stresses that may arise when loading substructure, use fixed (two per panel) and sliding mounting points. Fixed Points enable free movement of the panels in relation to the substructure.

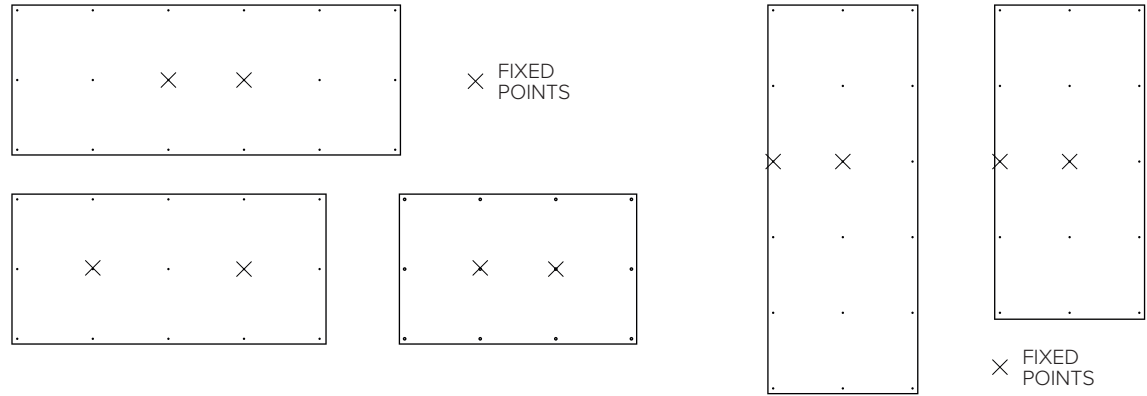

SELECTION OF THE WIDTH OF THE SUBSTRUCTURE PROFILES

When designing an aluminium / steel substructure, please select profiles enabling the connection of subsequent panels (T profile). Inter-panel profiles should be at least 100 mm wide. Profiles in the middle of the panels and corner profiles should be min. 50 mm wide.

HORIZONTAL MOUNTING ON VERTICAL SUBSTRUCTURE

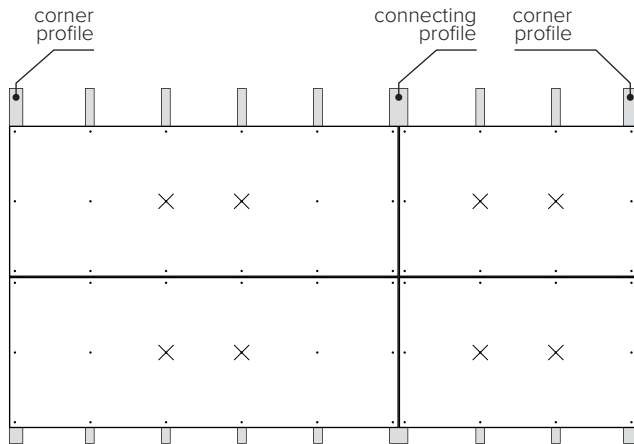

HORIZONTAL MOUNTING ON VERTICAL SUBSTRUCTURE WITH MOVING VERTICAL JOINING

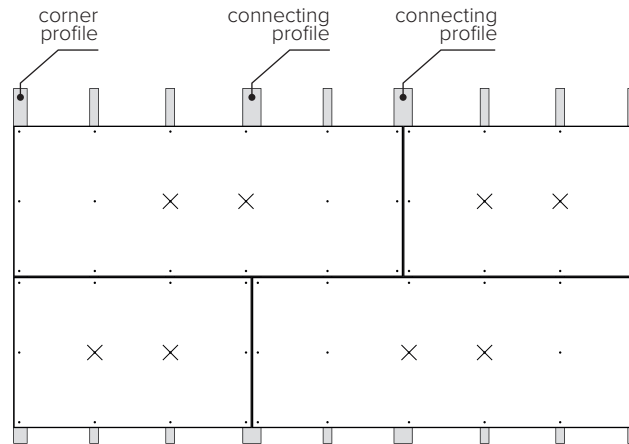

VERTICAL MOUNTING ON VERTICAL SUBSTRUCTURE

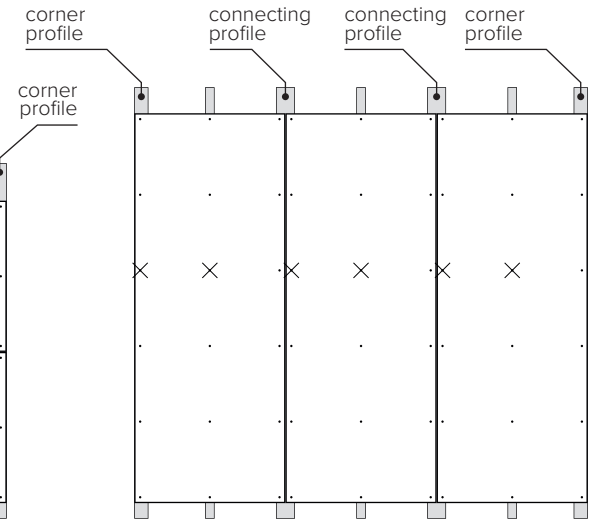



installation with blind rivets to the aluminum substructure

LAYOUT OF MOUNTING POINTS

- the distance between the two mounting points cannot exceed 600 mm vertically and horizontally
- the distance of the mounting holes from the vertical edges of the panel must not be less than 30 mm
- expansion joints between the panels should be at least 8 mm (the panel thickness)
- the minimum distance of the mounting points from the top edge of the panel cannot be less than 80 mm
- the minimum distance of the mounting points from the side and bottom edges of the panel must not be less than 30 mm

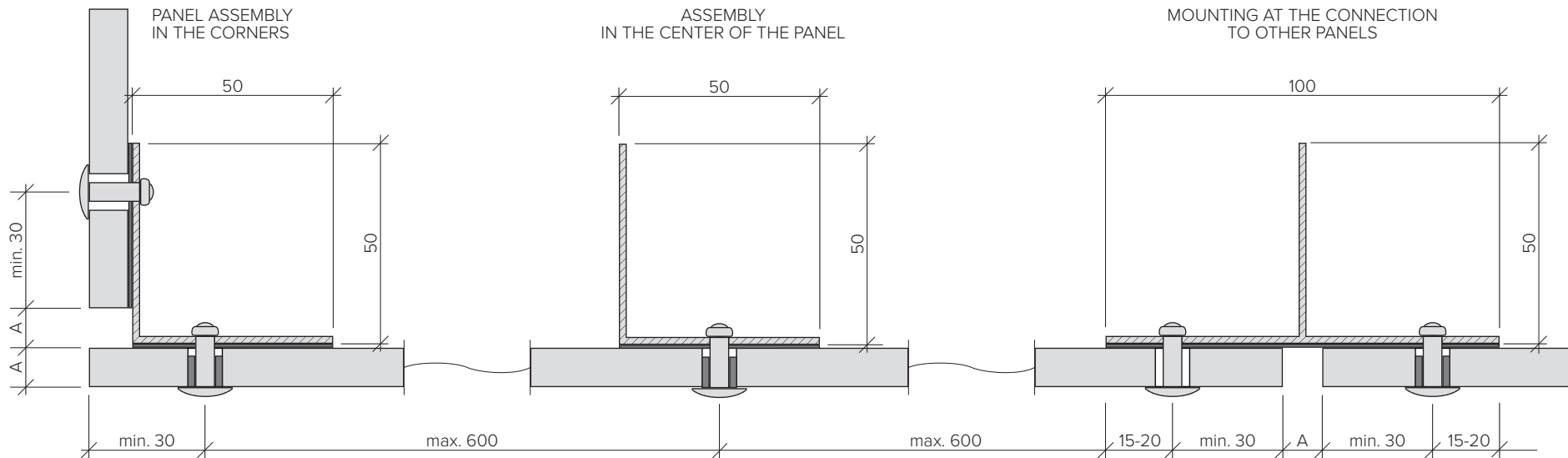
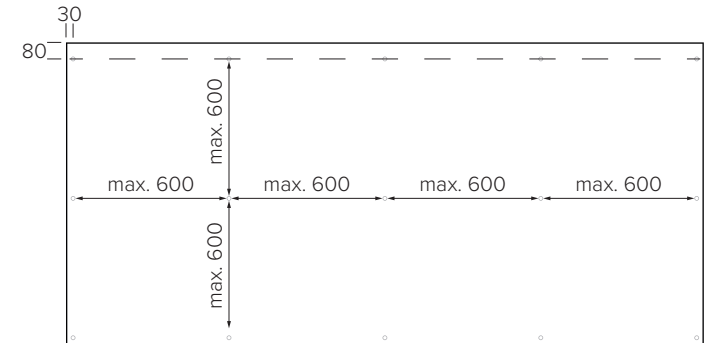

A - min. 8 mm | values are given in millimetres

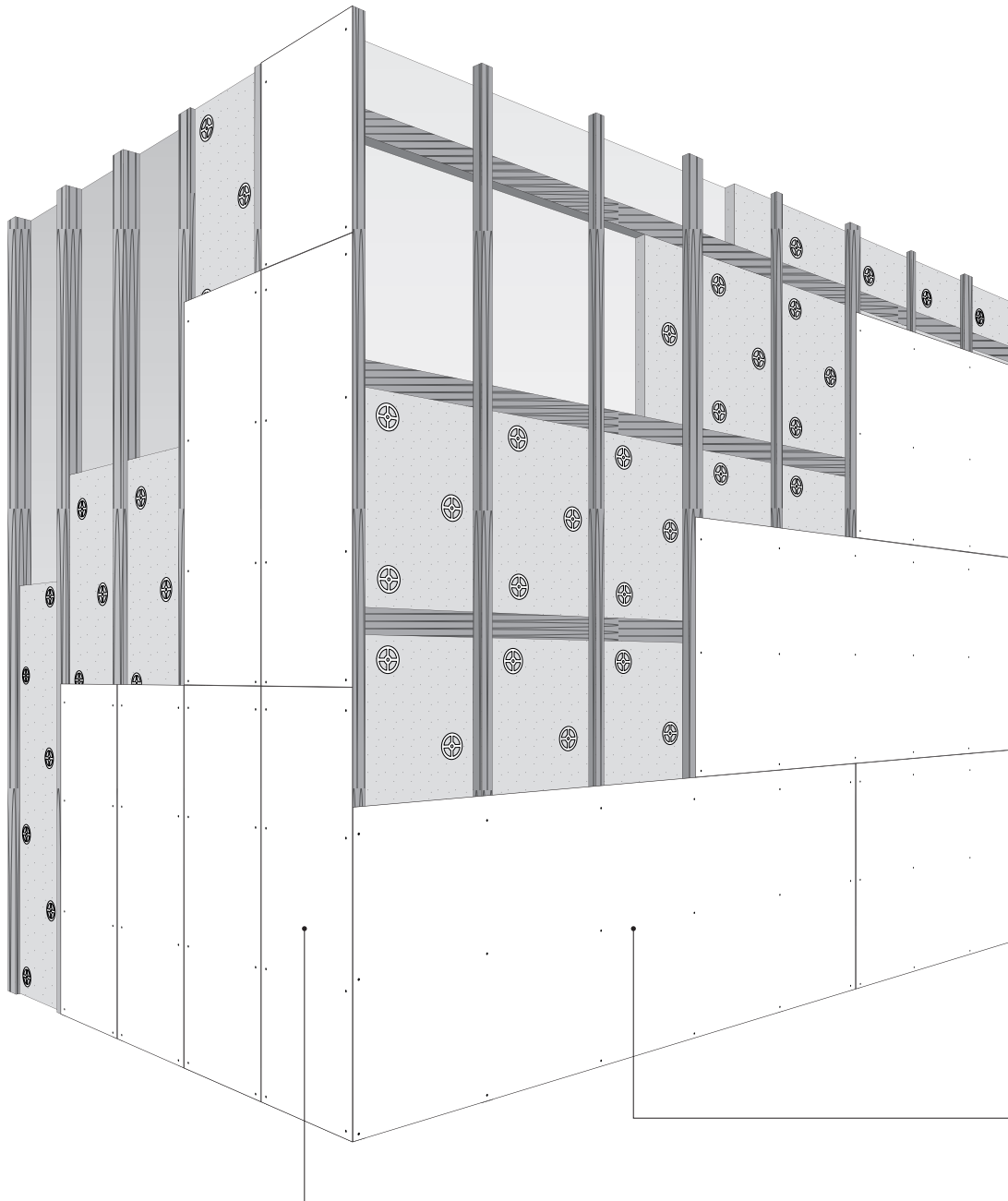

TYPE OF SUBSTRUCTURE

Mounting with screws can be used for wooden or aluminium substructures.

PANEL LAYOUT

The panels can be laid in a vertical or horizontal orientation.

If proper ventilation from below is not provided (e.g. the panel touches the substrate), the first ventilation grout should be located at a height of 60 cm.

panels mounted horizontally
on a vertical substructure

panels mounted vertically
on a vertical substructure

D

installation with screws

TOOLS AND ACCESSORIES

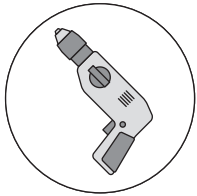

DRILL

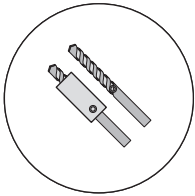

DIAMOND DRILL BITS
WITH AND WITHOUT LIMITER

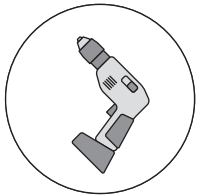

SCREWDRIVER

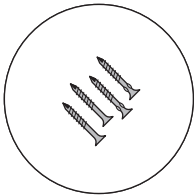

SCREWS

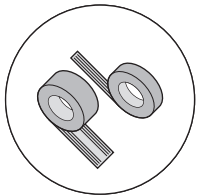

BACKING TAPE

PANEL MOUNTING

Mounting with screws to the prepared substructure, is made from the front of the panels and the screw heads remain visible.

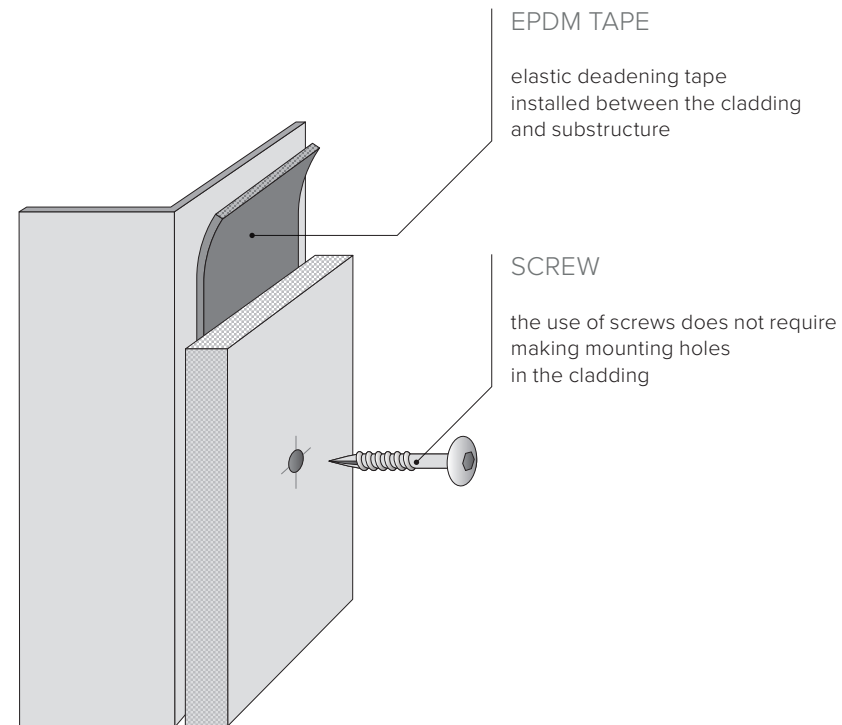

SCREW INSTALLATION

The panels are installed to the substructure with screws. FIXED and SLIDING mounting points are used in this type of connection (see page 22).

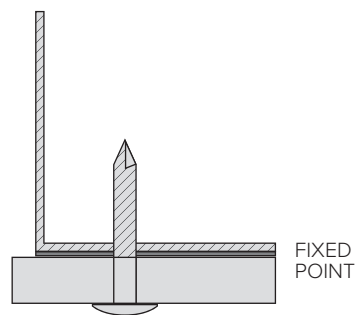
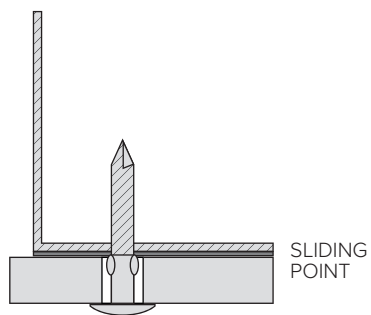
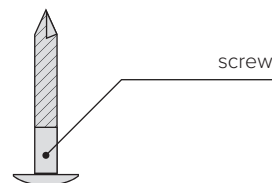
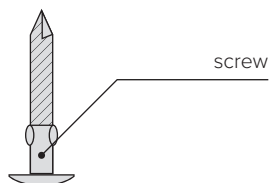
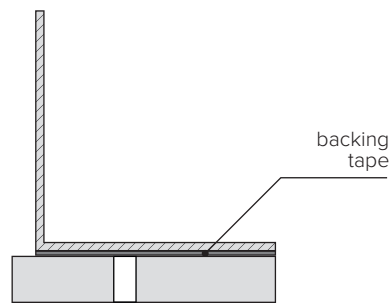
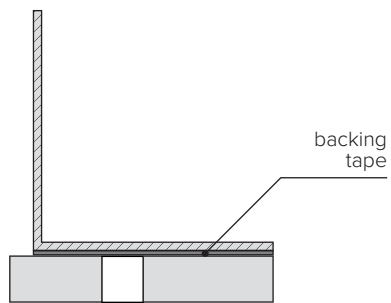
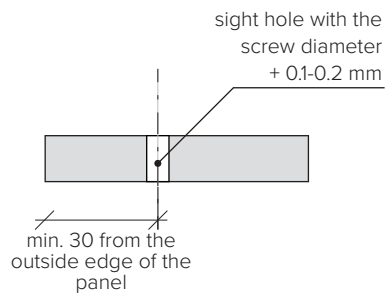
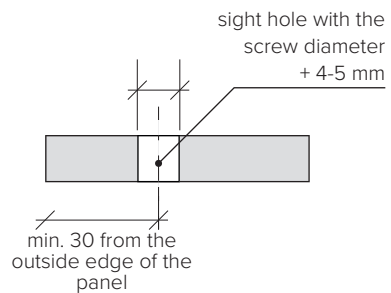

FIXED AND SLIDING MOUNTING POINTS

In order to avoid stresses that may arise when loading the substructure, fixed and sliding assembly points should be used. Fixed points position the panel and allow the panel to move freely relative to the substructure.

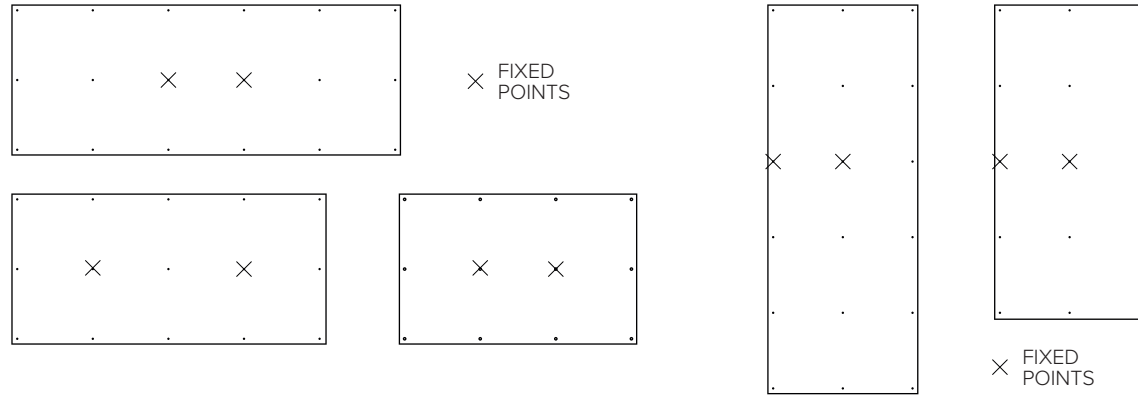

SELECTION OF THE WIDTH OF THE SUBSTRUCTURE PROFILES

When designing a wooden or aluminium / steel substructure, elements that ensure the possibility of joining subsequent panels should be selected. The connecting profiles should be at least 100 mm wide. Profiles in the middle of the panels and corner profiles should be min. 50 mm wide.

VERTICAL MOUNTING ON VERTICAL SUBSTRUCTURE

HORIZONTAL MOUNTING ON VERTICAL SUBSTRUCTURE

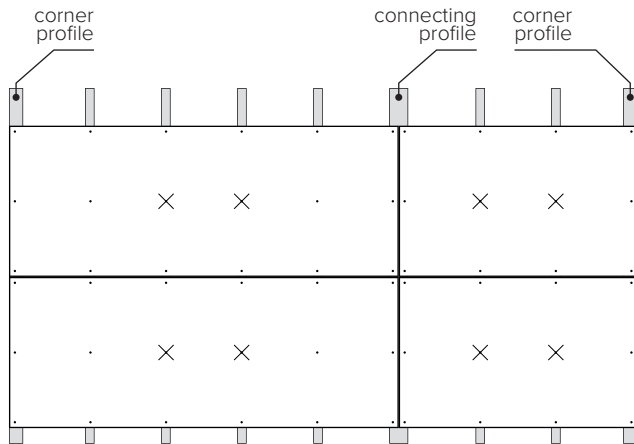

HORIZONTAL MOUNTING ON VERTICAL SUBSTRUCTURE WITH MOVING VERTICAL JOINING

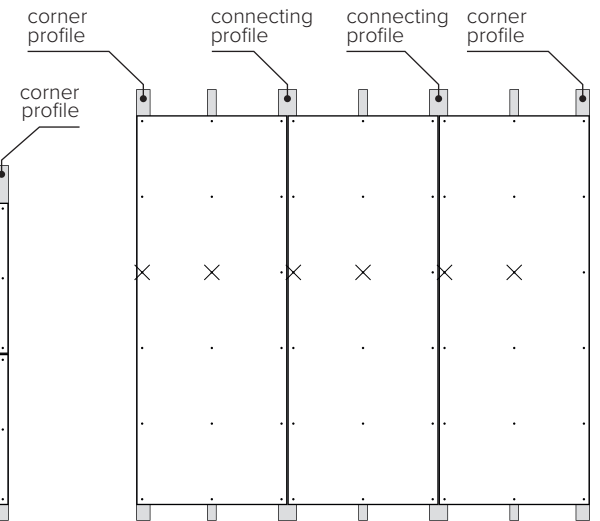
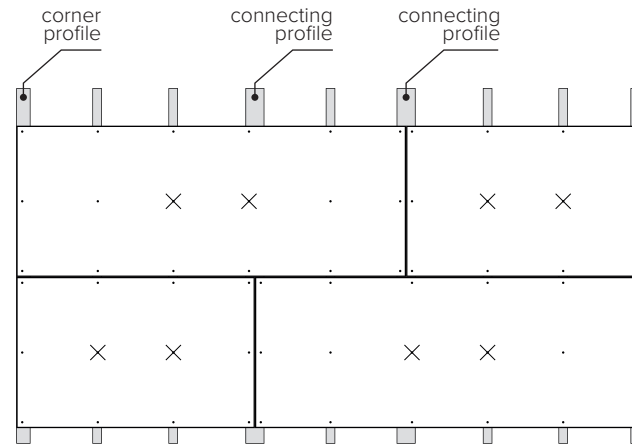

installation with screws to the aluminum substructure

LAYOUT OF MOUNTING POINTS

- the distance between the two mounting points cannot exceed 600 mm
- the distance between the mounting holes and the panel edge must not be less than 30 mm
- expansion joints between the panels should be at least 8 mm (the panel thickness)
- the minimum distance of the mounting points from the top edge of the panel cannot be less than 80 mm
- the minimum distance of the mounting points from the side and bottom edges of the panel must not be less than 30 mm

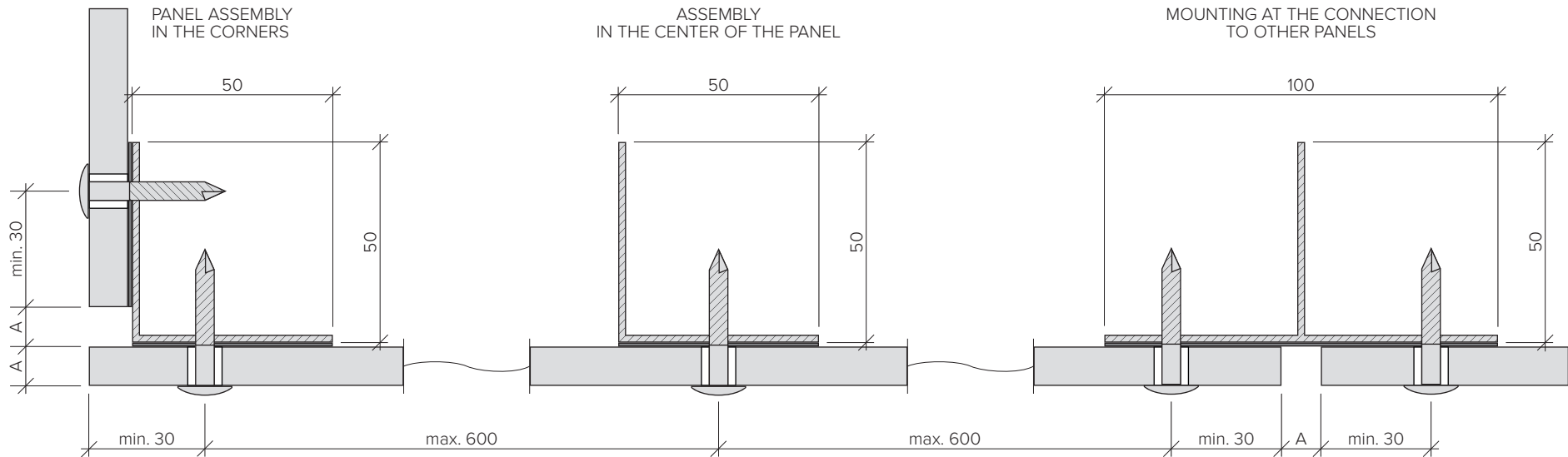
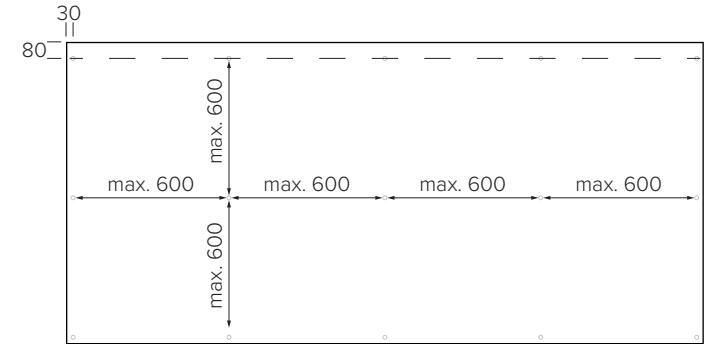

A - min. 8 mm | values are given in millimetres

LAYOUT OF MOUNTING POINTS

- the distance between the two mounting points cannot exceed 600 mm
- the distance between the mounting holes and the panel edge must not be less than 30 mm
- expansion joints between the panels should be at least 8 mm (the panel thickness)
- the minimum distance of the mounting points from the top edge of the panel cannot be less than 80 mm
- the minimum distance of the mounting points from the side and bottom edges of the panel must not be less than 30 mm

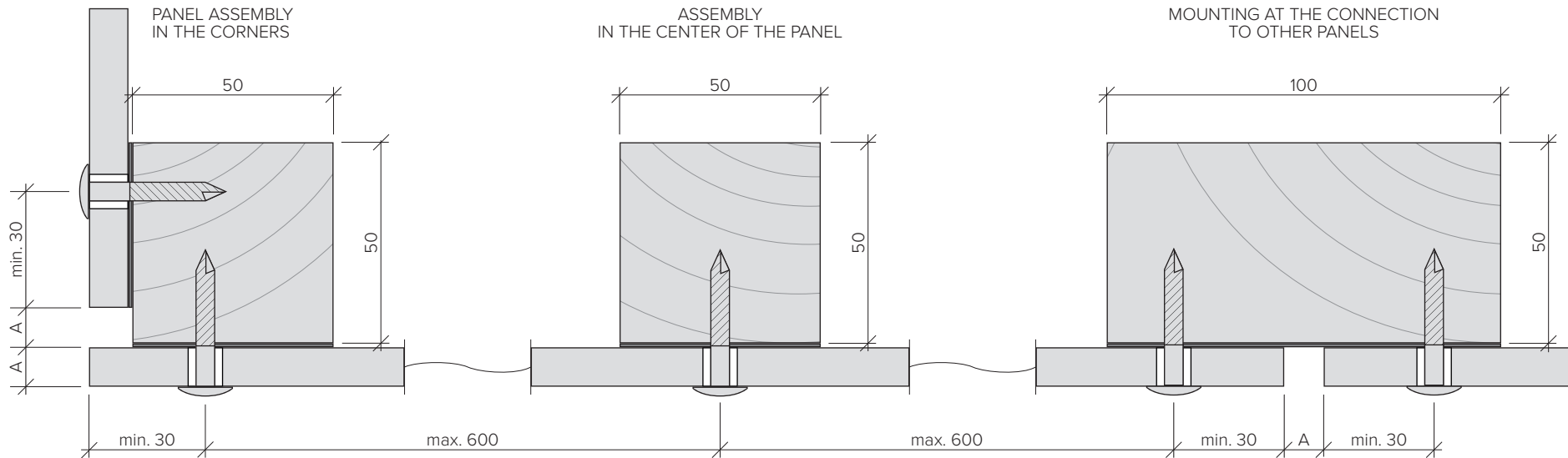
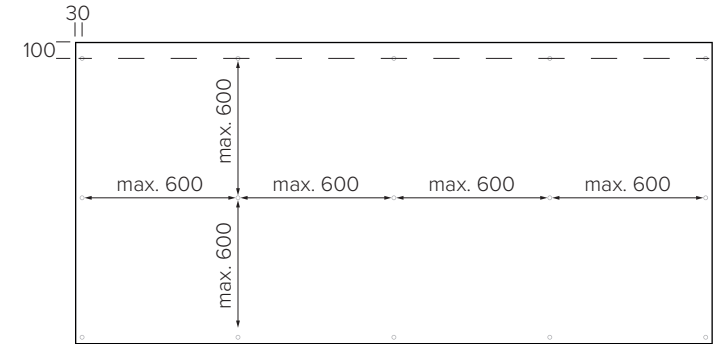

A - min. 8 mm | values are given in millimetres

PROFILES FOR FINISHING FACADES

For the aesthetic edge of facade cladding the family of finishing profiles is dedicated.

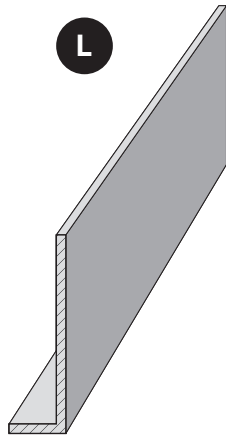

UNIVERSAL
L BATTEN

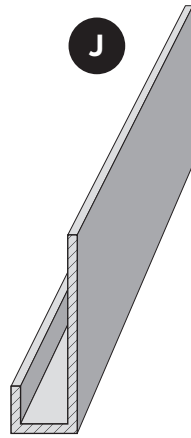
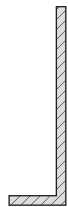

UNIVERSAL
J BATTEN

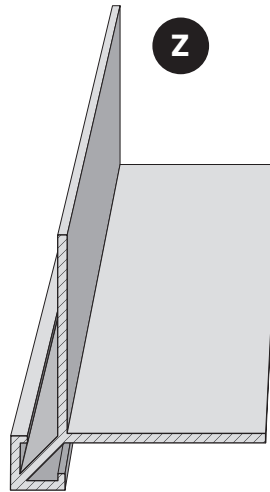

EXTERNAL V
CORNER BATTEN

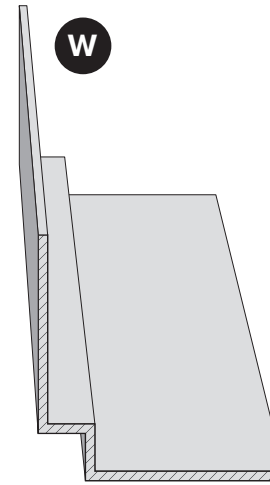
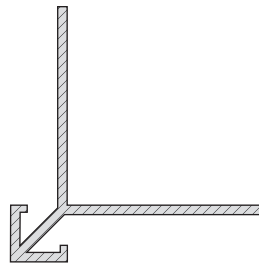

INTERNAL W
CORNER BATTEN

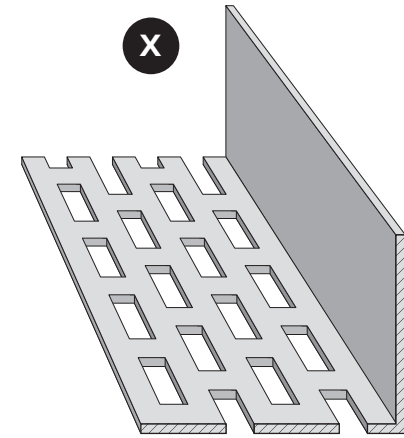
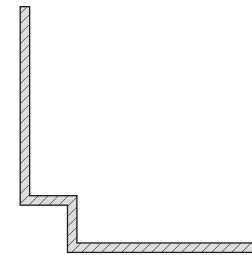

VENTILATION PROFILE

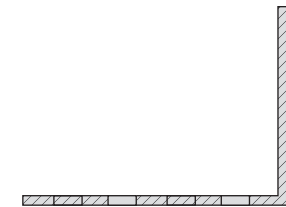

use of finishing profiles on the facade

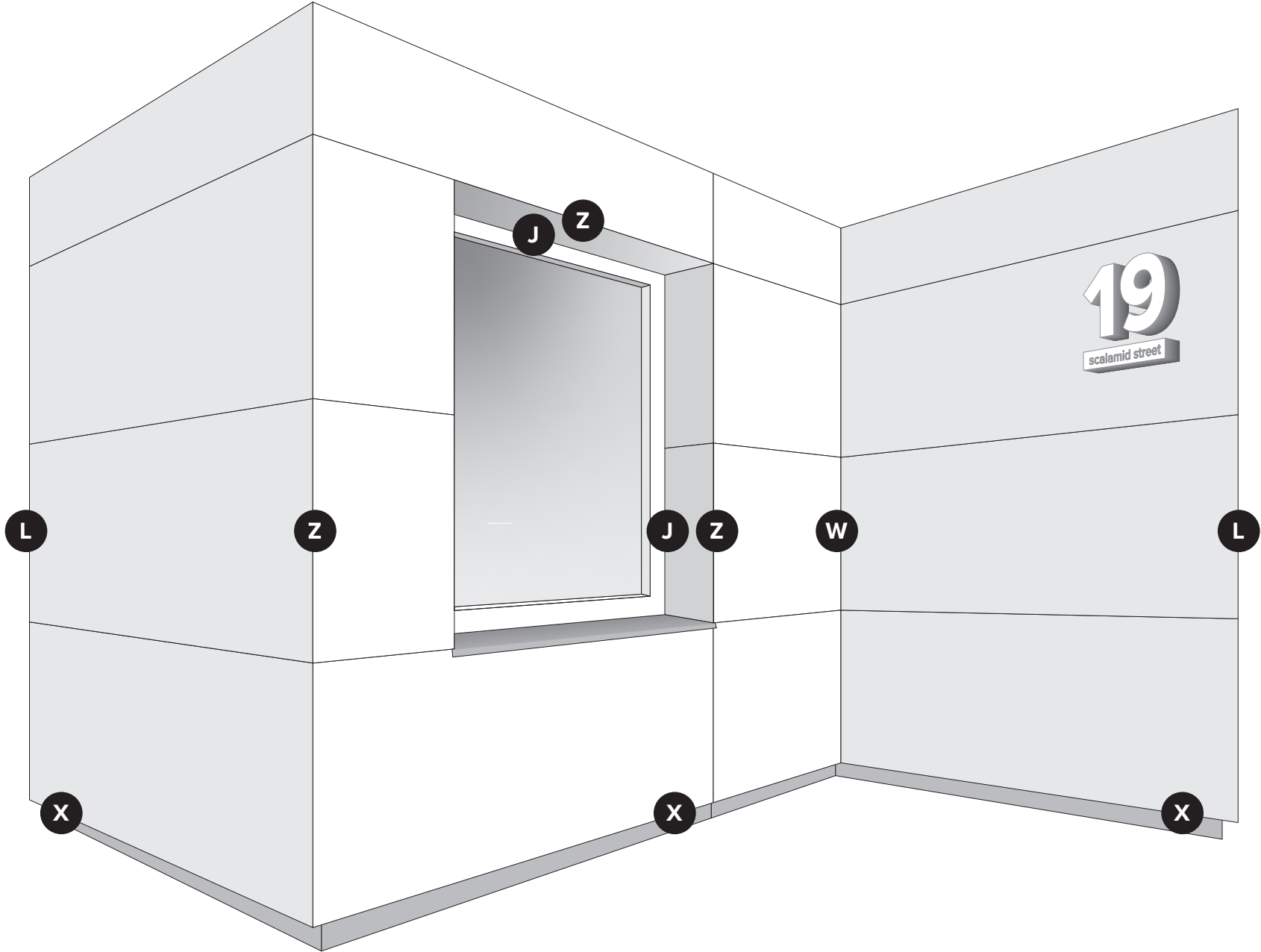

use of finishing profiles on the facade

USE OF A START PROFILE AND UNIVERSAL L BATTEN

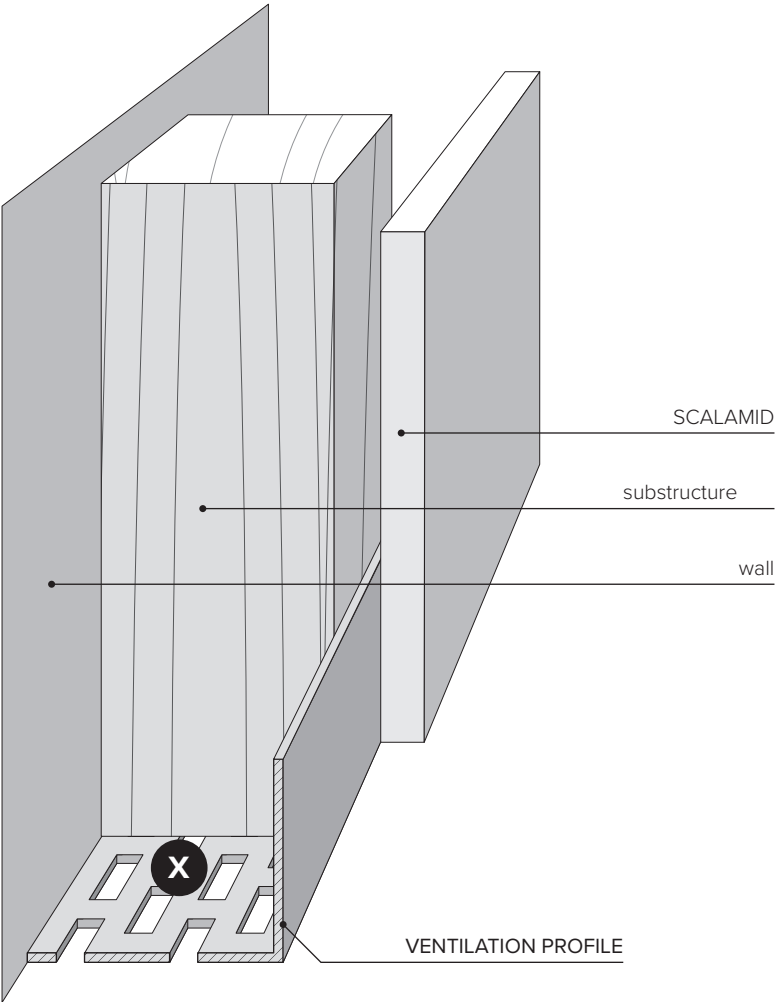

USE OF A START PROFILE AND UNIVERSAL J BATTEN

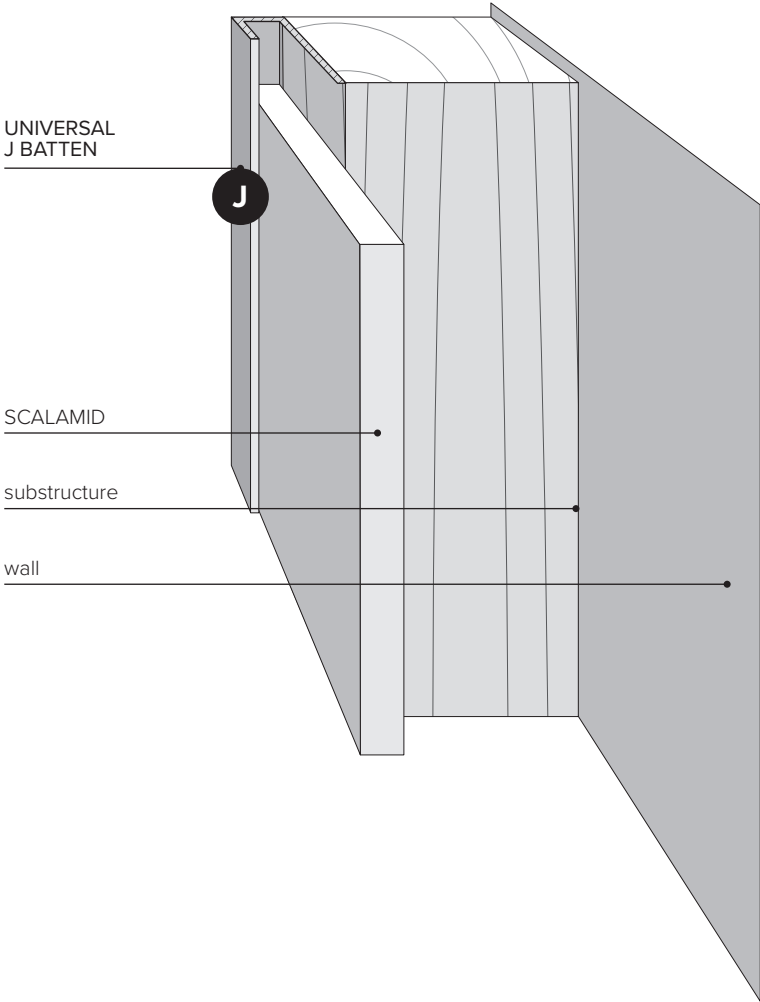

use of finishing profiles on the facade

THE METHOD OF FINISHING THE INTERNAL CORNERS WHEN USING THE CORNER BATTEN W

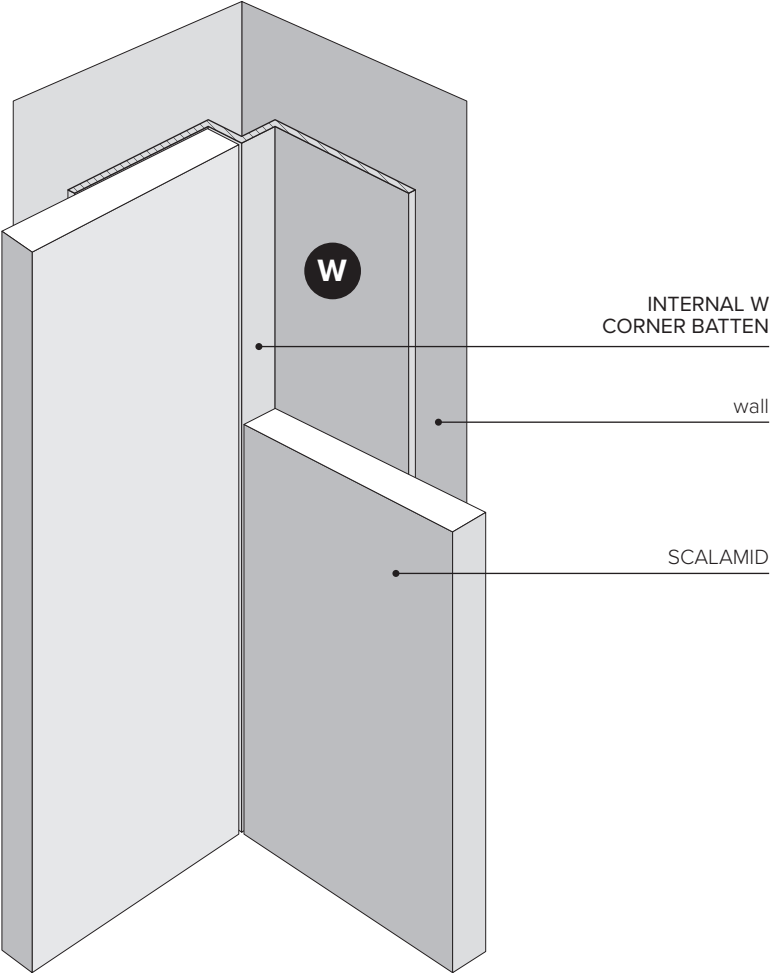

METHOD OF FINISHING EXTERNAL CORNERS WITH THE CORNER V BATTEN

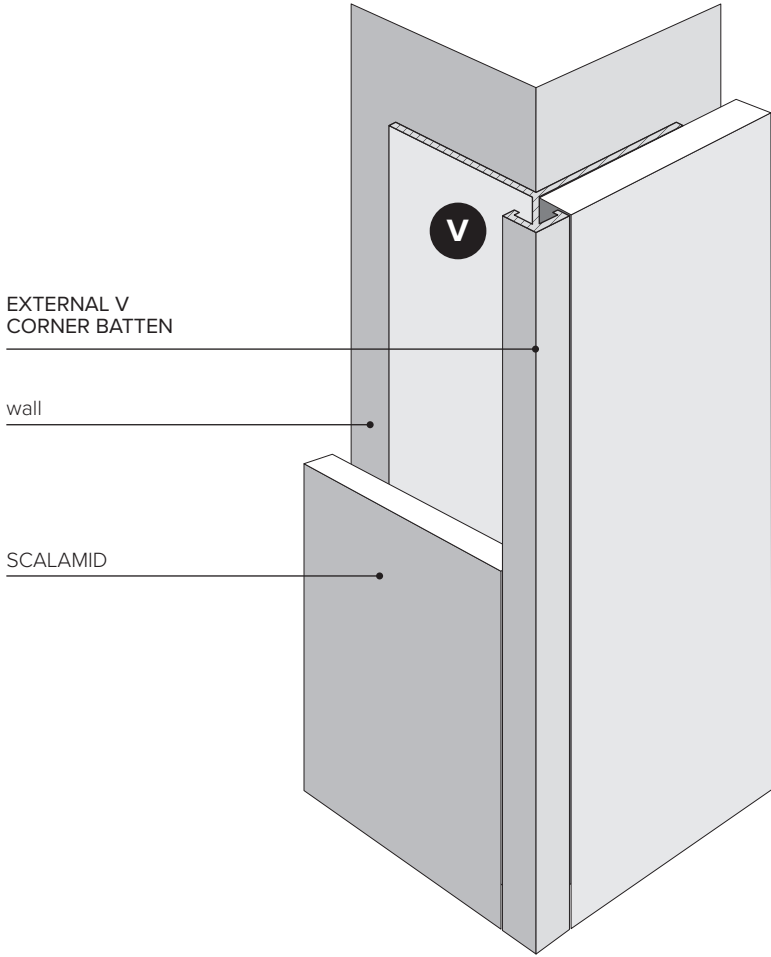

ways of finishing the corners of the walls

METHODS OF FINISHING EXTERNAL CORNERS
USING A UNIVERSAL ANGLE

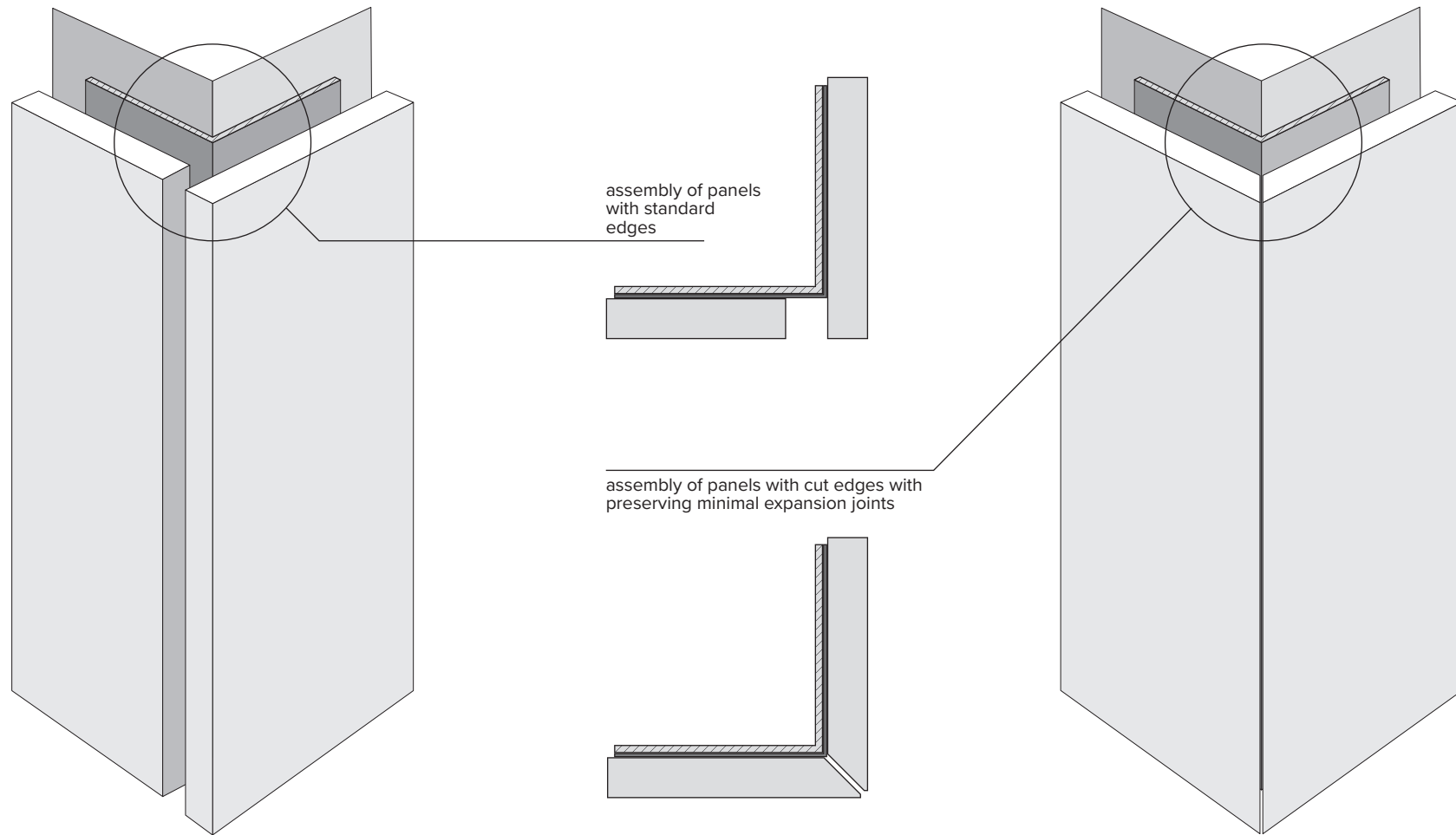

ways of finishing the corners of the walls

METHODS OF FINISHING INTERNAL CORNERS
USING A UNIVERSAL ANGLE

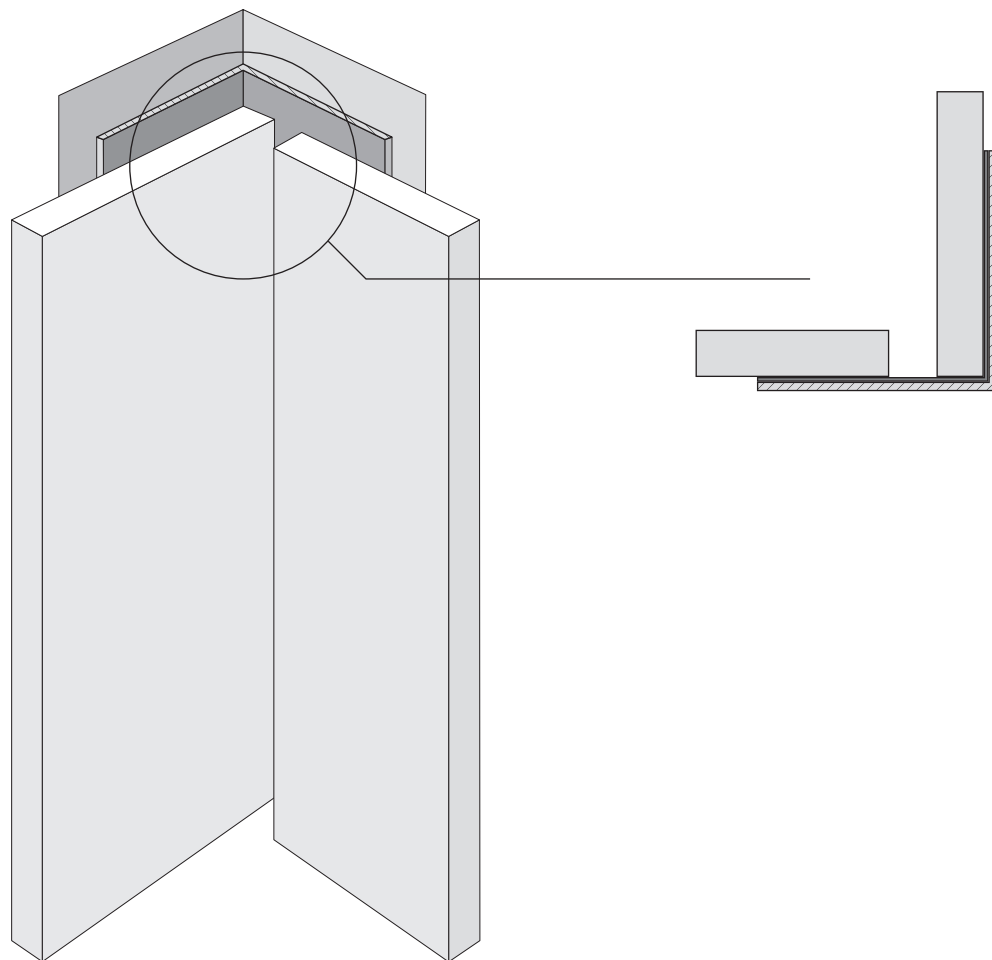

construction details of ventilated facades on the aluminum substructure

EXAMPLE OF A CONSTRUCTION SOLUTION
PANEL CONNECTIONS (BOTTOM VIEW)

EXAMPLE OF A CONSTRUCTION SOLUTION
EXTERNAL CORNER (BOTTOM VIEW)

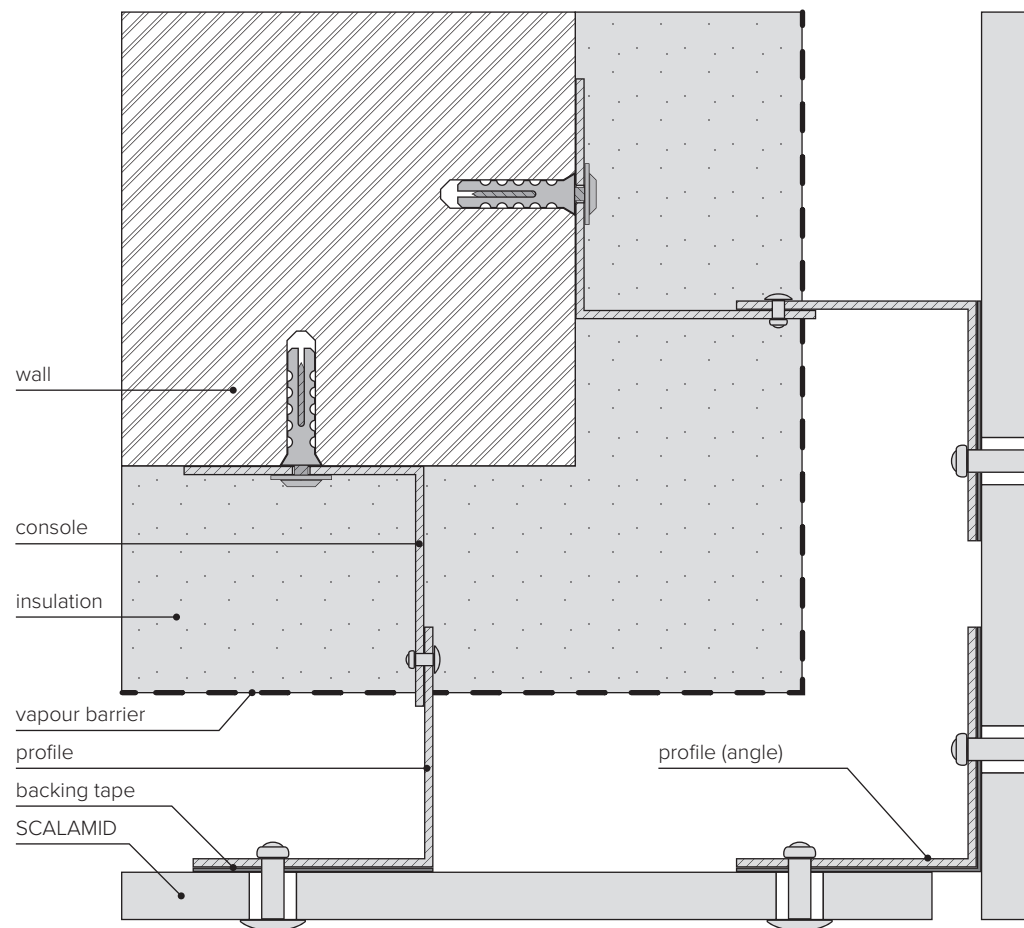
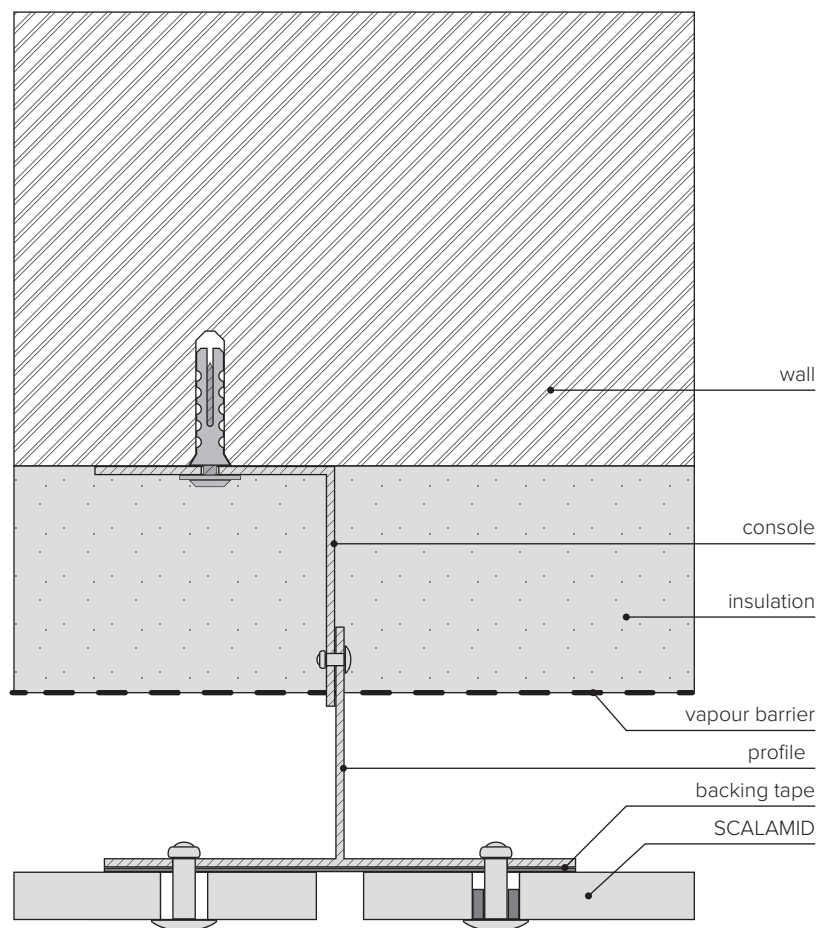

construction details of ventilated facades on the aluminum substructure

EXAMPLE OF A CONSTRUCTION SOLUTION
OF AN INTERNAL CORNER

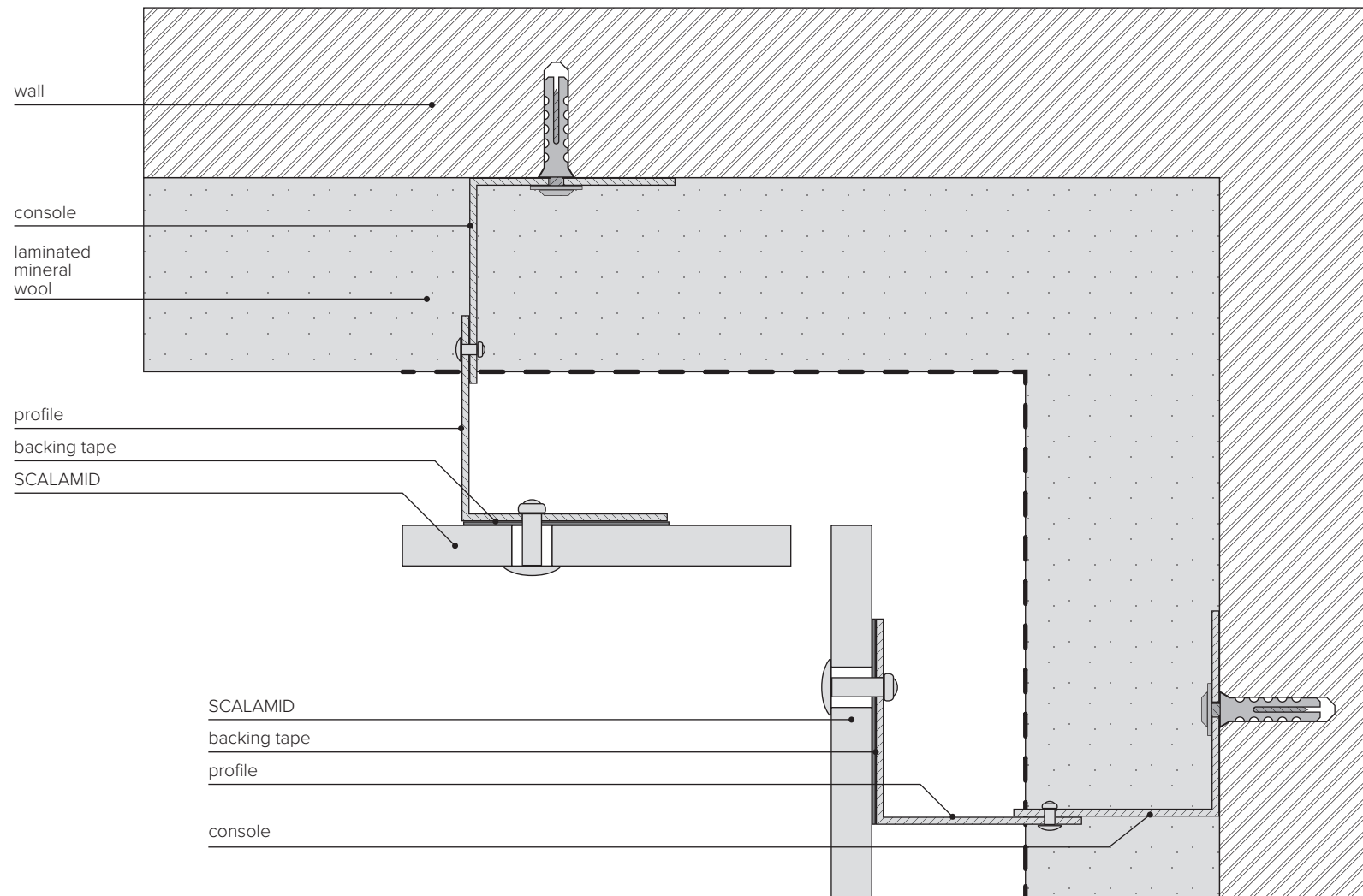

construction details of ventilated facades on the aluminum substructure

EXAMPLE OF APPLICATION OF VENTILATION PROFILES IN THE CONSTRUCTION OF A VENTILATED FACADE

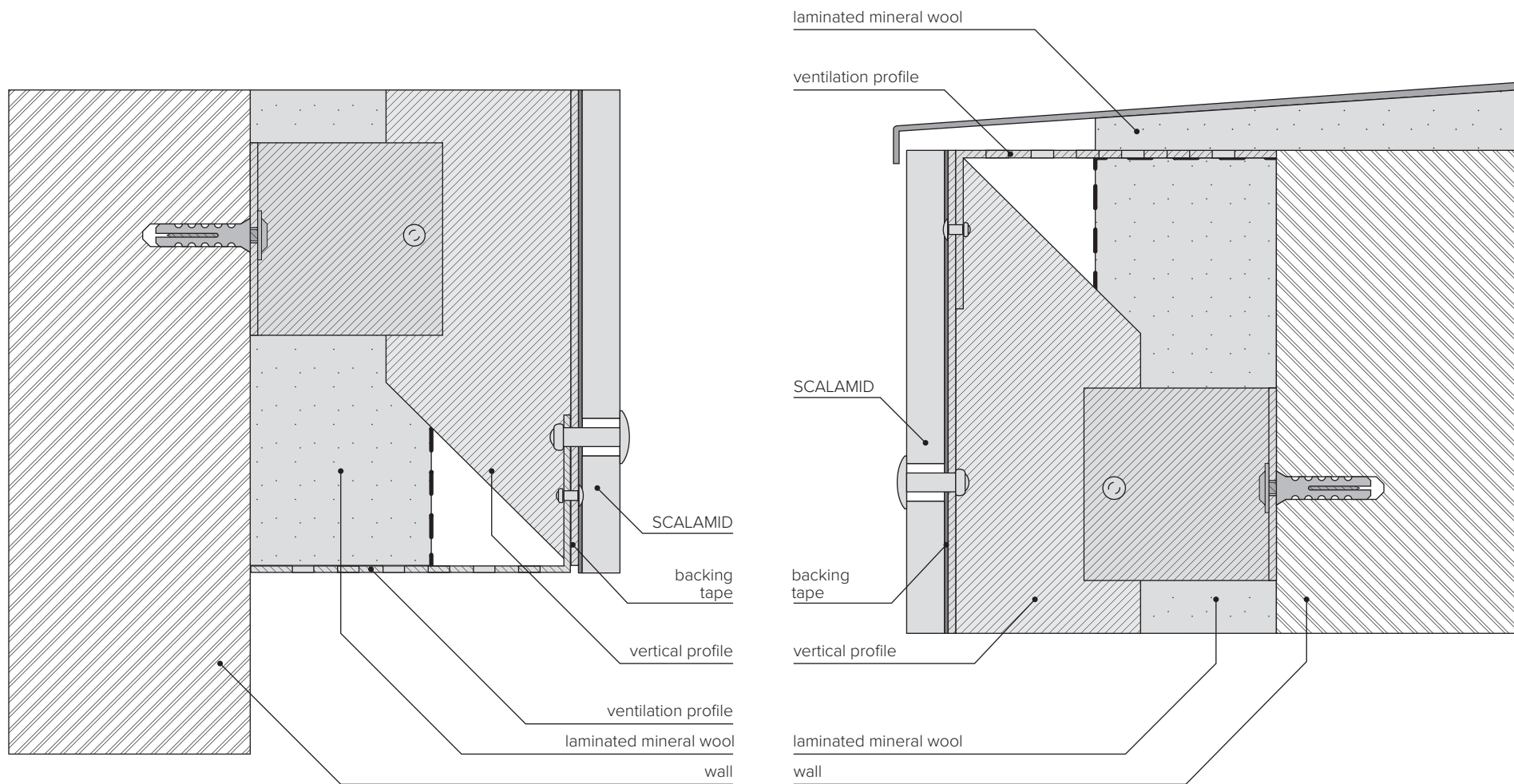

construction details of ventilated facades on an aluminum substructure

EXAMPLE OF A CONSTRUCTION SOLUTION
FOR FINISHING OF THE WINDOW

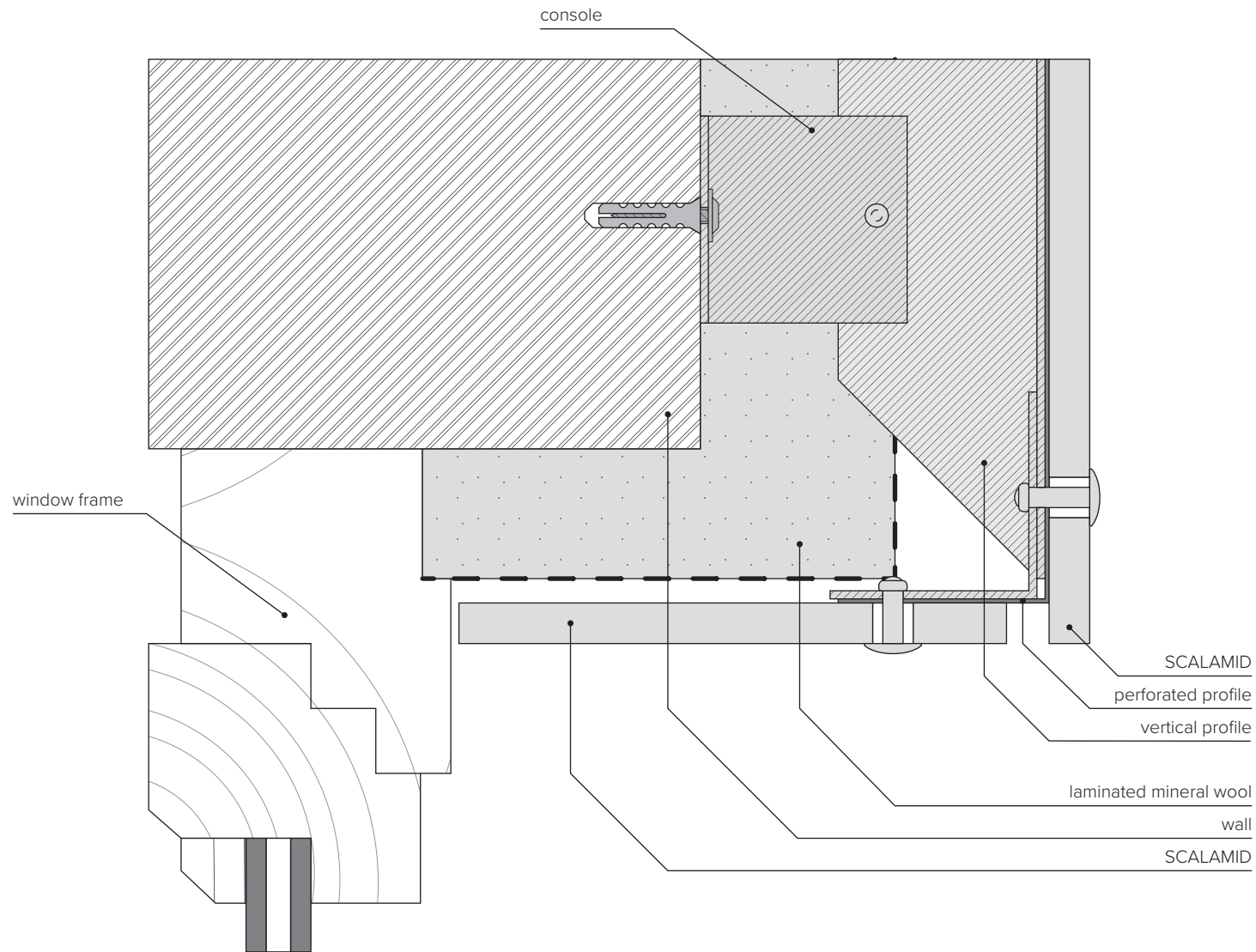

construction details of ventilated facades on the wooden substructure

EXAMPLE OF A CONSTRUCTION SOLUTION
PANEL CONNECTIONS

EXAMPLE OF A CONSTRUCTION SOLUTION
OF AN EXTERNAL CORNER

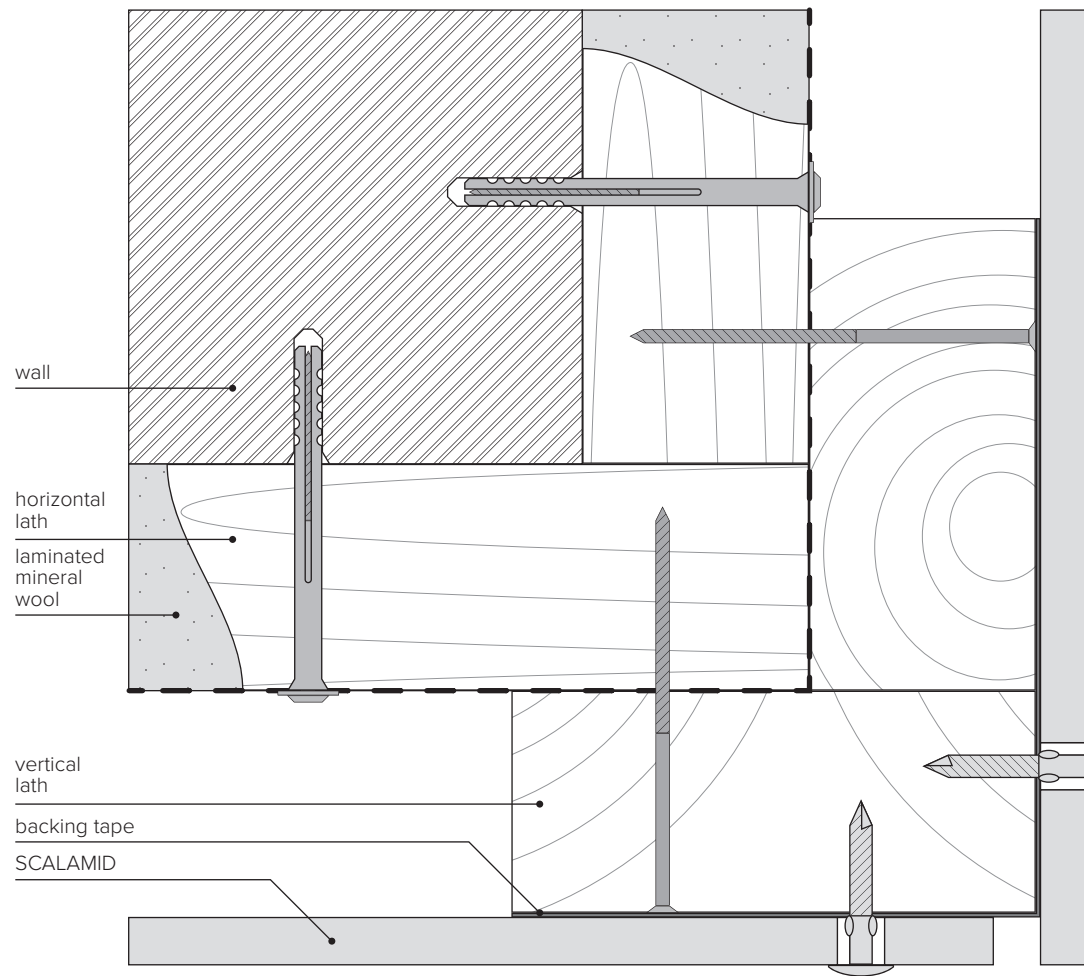
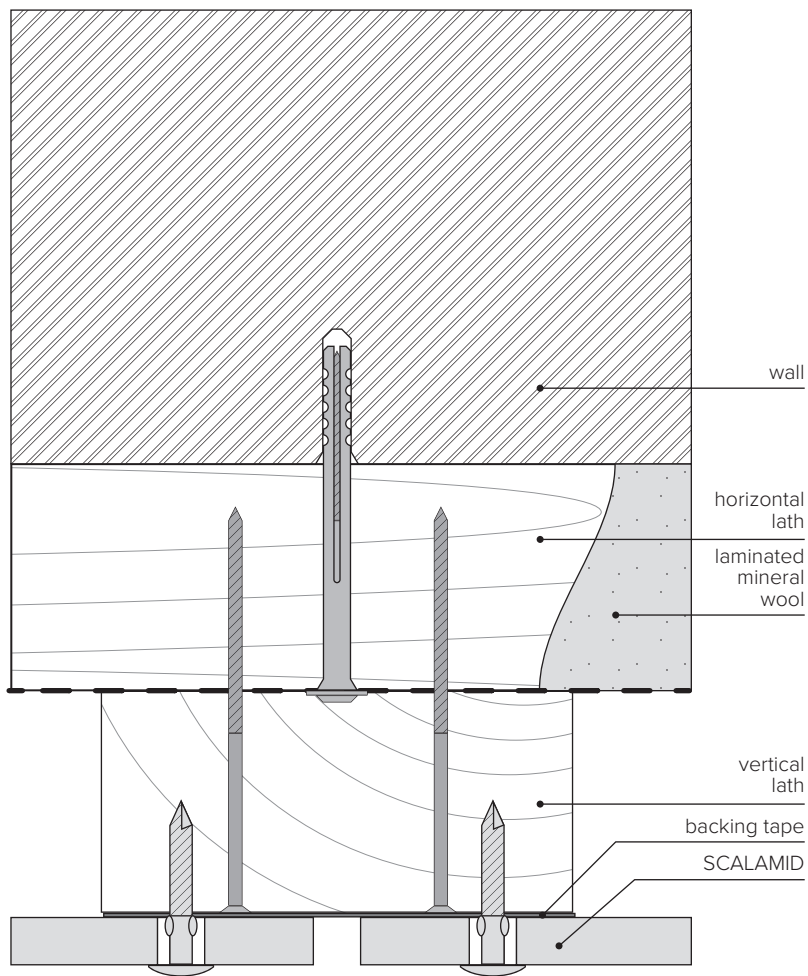

construction details of ventilated facades on the wooden substructure

EXAMPLE OF A CONSTRUCTION SOLUTION
OF AN INTERNAL CORNER

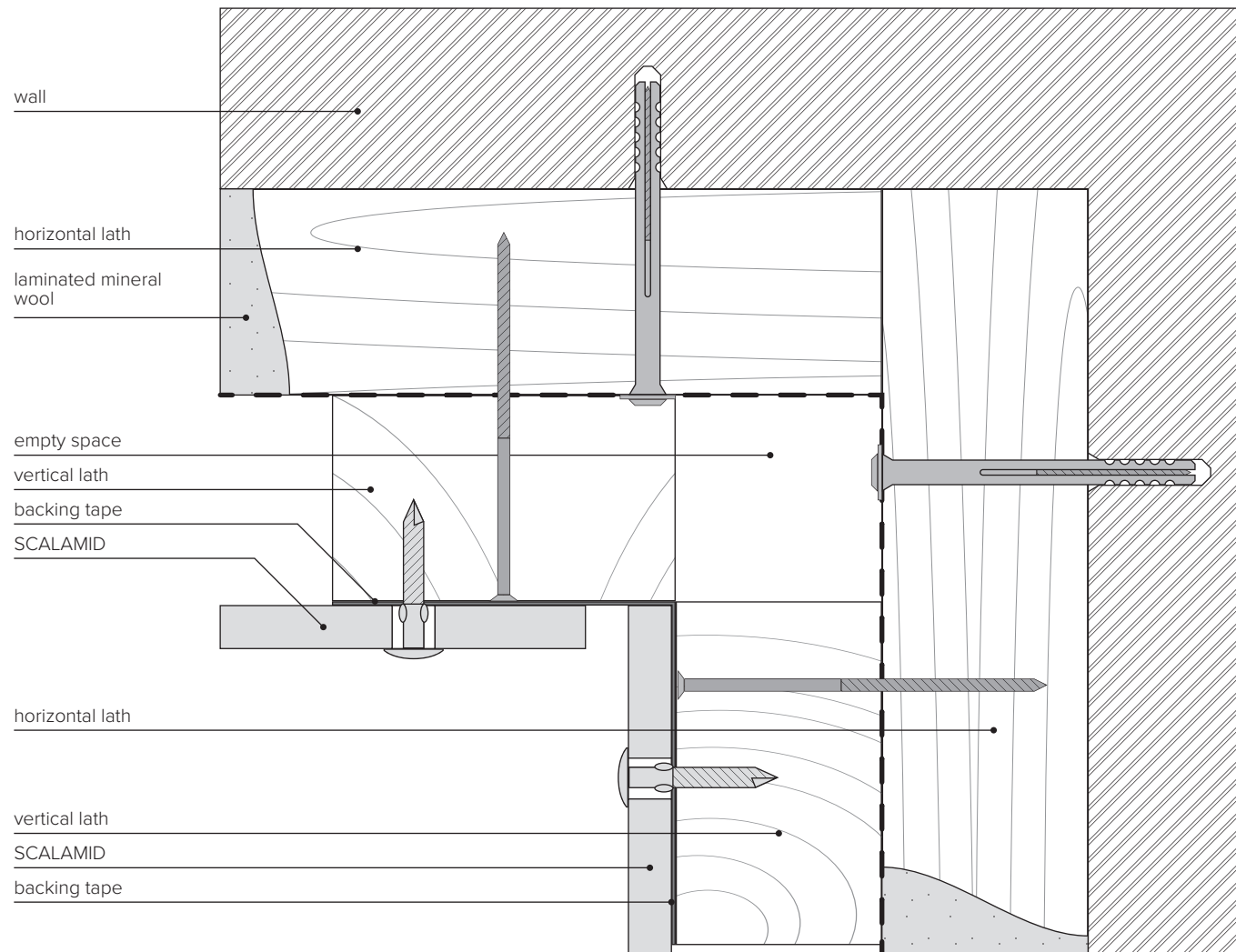

construction details of ventilated facades on the wooden substructure

EXAMPLE OF APPLICATION OF VENTILATION PROFILES IN THE CONSTRUCTION OF A VENTILATED FACADE

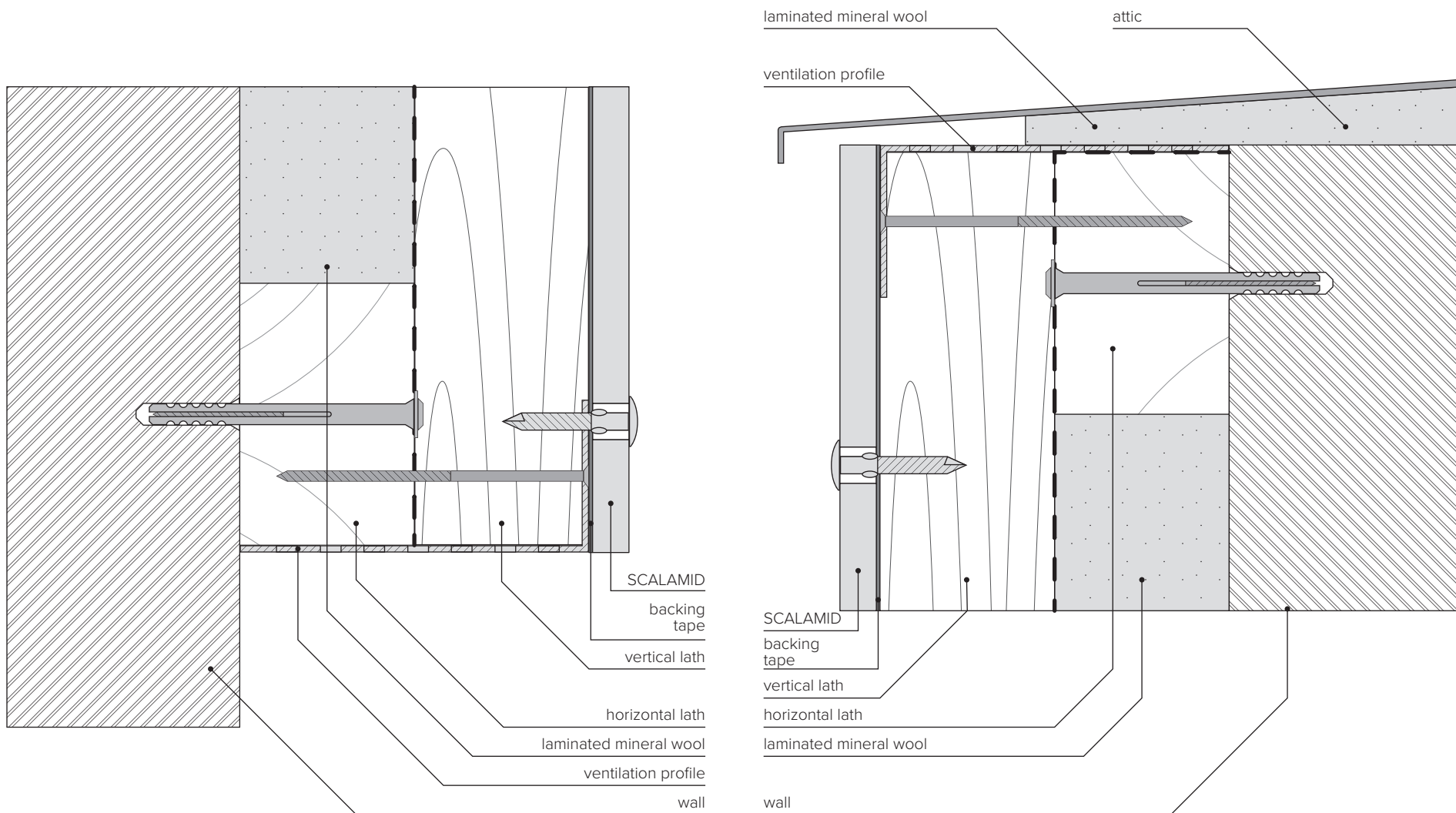

construction details of ventilated facades on the wooden substructure

EXAMPLE OF A CONSTRUCTION SOLUTION
FOR FINISHING OF THE WINDOW

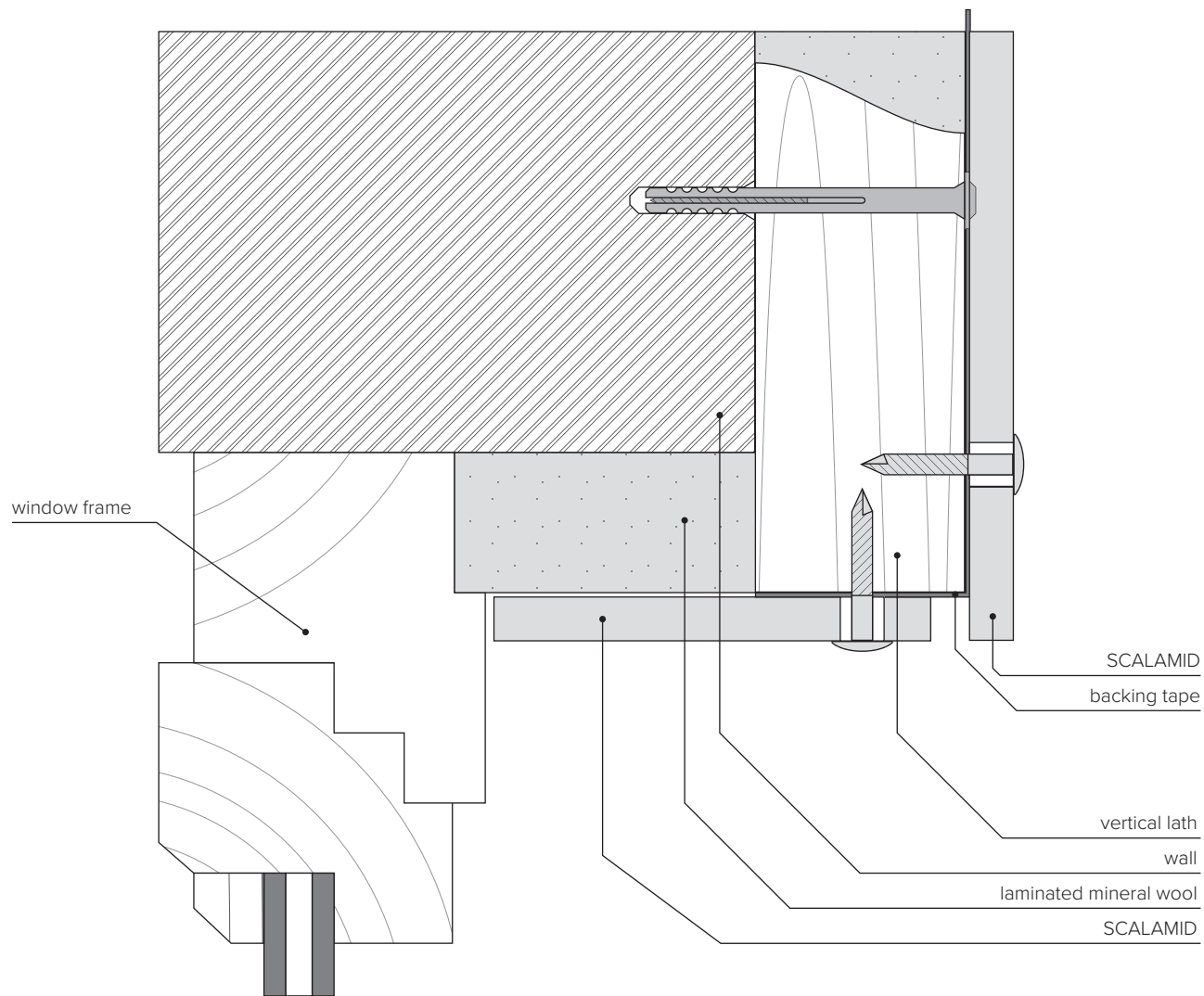



SCALAMID

FACADE • FLOOR • WALL

The above instruction is for reference only and does not cover all aspects related to the installation of panels in the system of ventilated facades. Details related to the specific design relating to the substructure or insulation, installation should be agreed in detail with the substructure and insulation supplier or company responsible for the installation.

Correct execution of the substructure, based on the detailed design prepared by the manufacturer of the substructure or an authorized designer, has a direct impact on the single plane of the facade (deviations in the plane between individual panels). The maximum deviation of the substructure is 1 mm / 2 m (deviation measured using a geodetic method). The designed substructure should have certificates.

Fibre-cement panels, like all other facade materials, are a product that naturally „moves“ on the facade under the influence of weather conditions. This fact should be taken into account at the stage of designing the ventilated facade. All solutions should be consulted with the designer of the substructure or the manufacturer of the facade cladding.

Scalamid is not responsible for any problems resulting from the use of materials and accessories that are not part of the manufacturer's offer.

We reserve the right to change the factual content of the manual at any time without prior notice.

www.scalamid.com